

AD-1653

SPECIFIC GRAVITY MEASURING KIT

INSTRUCTION MANUAL

Instruction-AD-1653-v.1.a 93.08.30

SPECIFIC GRAVITY MEASURING KIT

AND

A&D Company, Limited



Table of Contents

Best Conditions for Measuring

1. <i>The Kit Includes</i>	page 1•1
2. <i>Principle of Density Measurement</i>	page 1•2
Density	page 1•2
Specific Gravity	page 1•2
Archimedes' Principle of Density Measurement	page 1•2
Density of a Solid	page 1•3
Density of a Liquid	page 1•3
3. <i>Error Factors</i>	page 1•4
Buoyancy of Air	page 1•4
Temperature of Liquid	page 1•4
Volume of Float	page 1•5
Influence of Wire	page 1•5
Surface Tension	page 1•6
Bubbles	page 1•6
4. <i>Measuring the Density of a Solid</i>	page 1•7
Assembling the Kit (FR Series)	page 1•7
Assembling the Kit (HA Series)	page 1•8
Assembling the Kit (HX-100)	page 1•9
Assembling the Kit (FX-300, FA-200)	page 1•10
Measuring the Density of a Solid	page 1•11
5. <i>Measuring the Density of a Liquid</i>	page 1•13
Assembling the Kit	page 1•13
Measuring the Density of a Liquid	page 1•14



Welcome!

Thank You for Your AND Purchase!

This is the Instruction Manual for the AD1653 Specific Gravity Measuring Kit.

The AD1653, when combined with our electronic balance (FR Series, HA Series, HX-100, FX-300, or FA200), allows the density of a solid and liquid to be measured easily.

Before using the AD1653, please read this manual thoroughly.

Best Conditions for Measuring

- This specific gravity measuring kit allows the density or specific gravity of a solid or liquid to be measured. However, the results of measurements may be affected by various factors that could cause errors, thus can not be guaranteed.
- Do not use the specific gravity measuring kit for measuring the density or specific gravity of chemically active substances.
- After using the specific gravity measuring kit, clean all surfaces to remove rust and oxides.
- A balance is a precision instrument, so avoid shocks or excessive loads.
- Maintain the air, sample and water at a constant temperature during the measurement.

Specific Gravity Measuring Kit



Float
00: B44342A



Wire
00: B49799

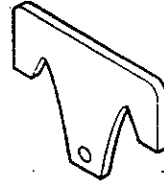

Float hook
04: C42200



Thermometer
00: B44813A

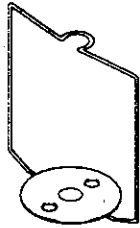

Pan stand
09: B31161A

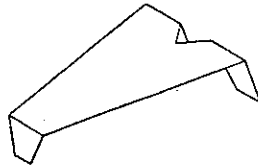

Beaker stand
04: B31158

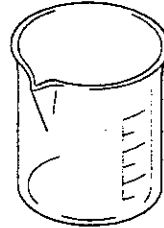

Beaker
10: PYLEX-300ML

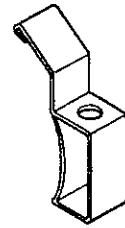

Thermometer clamp
10: 1-608-02



Pan
PM: 1653-1



Attachment for FX
05: C42219



Attachment for HX
05: C42220

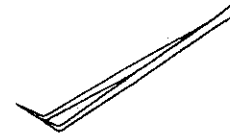

Tweezers
10: SHIKAYO

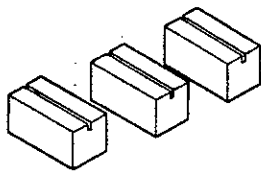

Beaker stand spacer
05: C42223 Three pieces

After use, store the components in the kit box.

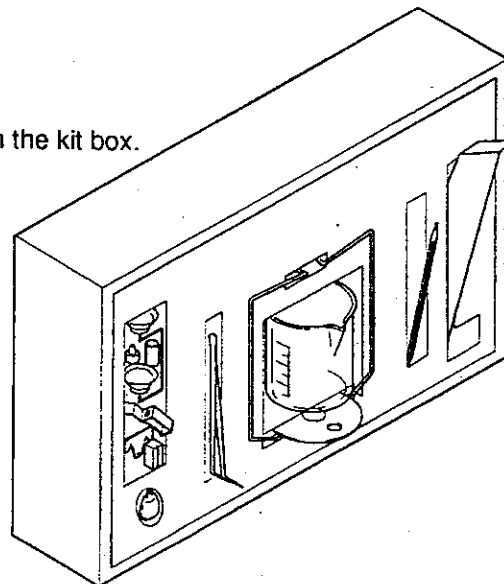

Kit box

2. Principle of Density Measurement

Density

Density refers to the total amount of mass of a sample per unit volume.

$$\rho = \frac{M}{V} \text{ (Unit: g/cm}^3\text{, etc.)}$$

ρ : Density

M: Mass

V: Volume

Specific Gravity

Specific gravity refers to the ratio of the density of a sample to the density of pure water (with the same volume as that of the sample) at 4°C at 1013.25 hPa.

$$S = \frac{M}{V \cdot \rho_4} \text{ (No unit)}$$

S: Specific gravity

M: Mass

V: Volume

ρ_4 : Density of water at 4°C (0.99997 g/cm³ \approx 1.000 g/cm³)

Archimedes' Principle of Density Measurement

Archimedes' Principle

A body immersed in a fluid undergoes an apparent loss in weight equal to the weight of the fluid it displaces.



The AD1653 is combined with an electronic balance to measure the density of a specimen, based on the Archimedes' principle.

Density of a Solid

The density of a solid can be obtained according to the weight of the specimen in air and the density of the liquid.

$$\rho = \frac{A}{A-B} \times \rho_0$$

ρ : Density of specimen

A: Weight in air

B: Weight in liquid

ρ_0 : Density of liquid

Density of a Liquid

The density of a liquid can be obtained according to the weight in air, weight in liquid, and volume of a float.

$$\rho = \frac{A-B}{V} + d$$

ρ : Density of liquid

A: Weight of float in air

B: Weight of float in liquid

V: Volume of float

d: Density of air (approx. 0.001 g/cm³)

3. Error Factors

- ▶ There are several things that can effect the accuracu of a density measurement.

Buoyancy of Air

-  ▶ When the density of a liquid is measured, an upward force of 0.0010 to 0.0014 g.cm³ is exerted .

- ▶ The buoyancy in air per 1 cm³ is found by:

$$d(\text{g/cm}^3) = \frac{0.0012932}{1+0.0036728 \times t(^{\circ}\text{C})} \times \frac{P}{1013.25}$$

t: Air temperature (°C)



P: Air pressure (hPa)

- ▶ When obtaining measurement results down to the third decimal place, 0.001 g/cm³ is added to the measured value to compensate for the air density error.

Temperature of Liquid

-  ▶ When the density of a solid is measured, the density of the liquid changes with its temperature. Therefore, the digit at the second decimal place of the measured density value involves an error.
- ▶ Obtain the density of a liquid by comparing its temperature with the values in Table 1 for distilled water or given in other reference documents for other liquids.
- ▶ If you want to obtain the measured value of the density of a solid down to the third decimal place, use a thermometer with a tolerance of ±0.2°C.



Volume of Float

-  The tolerance of the measured value of the volume of the float is $\pm 0.01 \text{ cm}^3$. When density is measured, the digit at the second decimal place of the measured density value involves an error.
-  If you want to obtain the measured value of density down to the third decimal place, measure the volume of the float using distilled water.

$$V = \frac{A - B}{\rho - d} \text{ (cm}^3\text{)}$$

A:	Weight of float in air	(g)
B:	Weight of float in water	(g)
V:	Volume of float	(cm ³)
ρ :	Density of distilled water at t°C	(g/cm ³)
d:	Buoyancy of air at t°C	(g/cm ³)

Influence of Wire

-  If the surface of the liquid rises 1 mm along the pan wire (1 mm in dia.) when a specimen is immersed in a liquid to measure the density of a solid, the buoyancy applied is about 0.8 mg. To minimize the rise in the liquid surface, select a specimen with a volume that will not raise the liquid surface so high.
-  When the wire (0.2 mm in dia.) to suspend the float is immersed in the liquid to measure the density of the liquid, a buoyancy of about 0.3 mg is exerted. However, this buoyancy can be ignored because it is divided by the volume of the float when the density of the liquid is obtained.



Surface Tension



- ▶ When the density of a solid is measured, a force of about 5 mg (surface tension) is applied to the pan between the wire (1 mm in dia.) of the pan and the surface of the liquid.
- ▶ The surface tension can be reduced to about 1 mg by adding a surface-active agent (for example, a water droplet preventive solution as used for developing photographs).

Adding 0.1 ml (1.2 g/cm³ density) of a surface-active agent to 200 ml of water will increase the density of the water by about 0.0001 (g/cm³).

- ▶ When the density of a solution is measured, a force of about 1 mg is exerted by the wire of 0.2 mm in diameter. However, this force can be ignored because it is divided by the volume of the float.



Bubbles



- ▶ The buoyancy of a bubble of 1 mm in diameter is about 0.5 mg. Stickiness of bubbles depends on the shape and material of a specimen. Make measurements considering these characteristics of bubbles.
- ▶ When the density of a solid is measured, a surface-active agent may be added to reduce the influence of bubbles.

4. Measuring the Density of a Solid

-  Assemble the kit as described in the procedure below. Note that the assembly procedure depends on the model of the balance combined with the AD1653.

Assembling the Kit (FR Series)

1 Disassemble the pan, pan support, windshield ring, and dust plate of the FR.

2 Set the pan stand on the FR.

3 Set the beaker stand so that it does not touch the pan stand.

4 Attach the thermometer clamp to the beaker and insert the thermometer in the thermometer clamp holes.

5 Pour a liquid (distilled water, etc.)—whose specific gravity is known—into the beaker and place the beaker on the beaker stand.

6 Place the pan on the pan stand.

7 Adjust the amount of the liquid so that the specimen is about 10 mm below the surface of the liquid with the specimen placed on the lower pan (in the liquid).

 When the value displayed on the FR becomes stable, press the **RE-ZERO** key to reset the displayed value to zero.

Preparations for measurement are now complete.

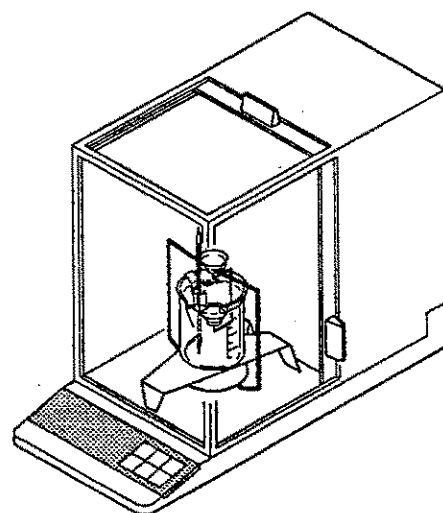
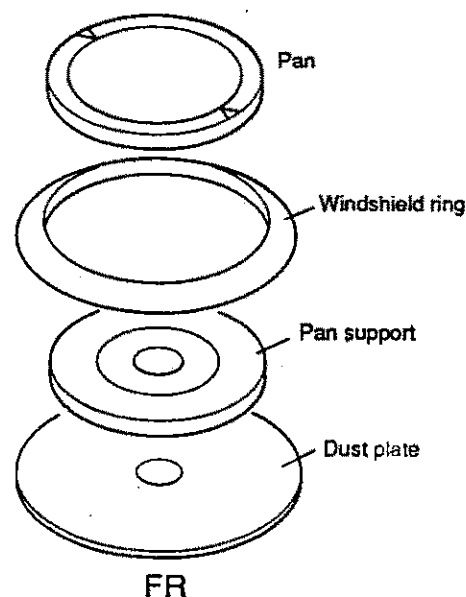

Assembling the Kit (HA Series)

 Position the doors of the HA for convenient use.

1 Disassemble the pan, balance weight, pan support, windshield ring, and dust plate of the HA.

2 Set the pan stand on the HA.

3 Place the HA balance weight from the pan set on the pan stand only for the HA202A.

4 Set the beaker stand so that it does not touch the pan stand.

5 Attach the thermometer clamp to the beaker and insert the thermometer in the thermometer clamp holes.

6 Pour a liquid (distilled water, etc.)—whose specific gravity is known—into the beaker and place the beaker on the beaker stand.

7 Place the pan on the pan stand.

8 Adjust the amount of the liquid so that the specimen is about 10 mm below the surface of the liquid with the specimen placed on the lower pan (in the liquid).

9 When the value displayed on the HA becomes stable, press the **RE-ZERO** key to reset the displayed value to zero.

Preparations for measurement are now complete.

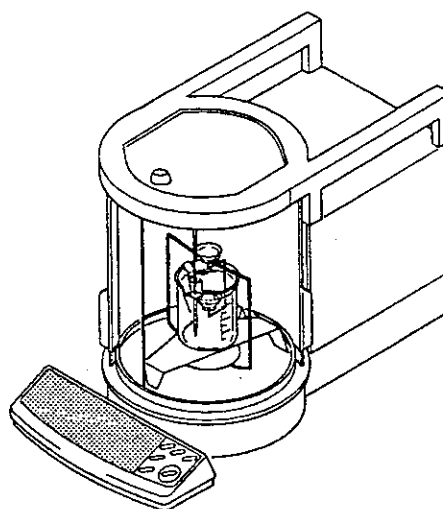
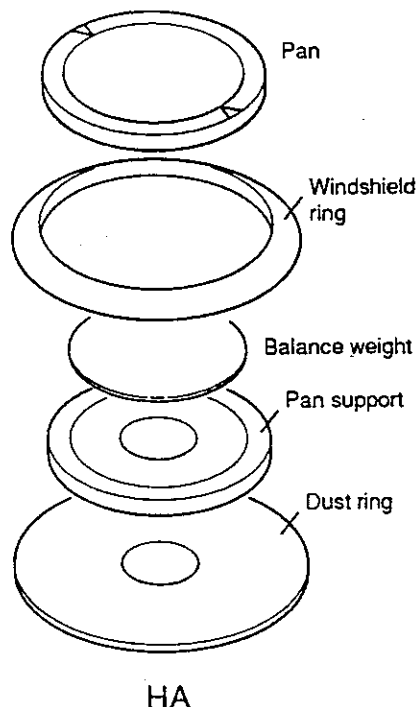

Assembling the Kit (FX-300, FA-200)

 Use the FX-300 or FA-200 with the optional top glass open, if it is attached.

1 Disassemble the pan and windshield ring.

2 Attach an FX attachment to the pan boss.

3 Set the pan stand on the balance.

4 Set the beaker stand so that it does not touch the pan stand and set beaker stand spacers under the beaker stand legs so that they fit into the grooves of the spacers.

5 Attach the thermometer clamp to the beaker and insert the thermometer in the thermometer clamp holes.

6 Pour a liquid (distilled water, etc.)—whose specific gravity is known—into the beaker and place the beaker on the beaker stand.

7 Place the pan on the pan stand.

8 Adjust the amount of the liquid so that the specimen is about 10 mm below the surface of the liquid with the specimen placed on the lower pan (in the liquid).

9 When the value displayed on the balance becomes stable, press the **RE-ZERO** key to reset the displayed value to zero.

Preparations for measurement are now complete.

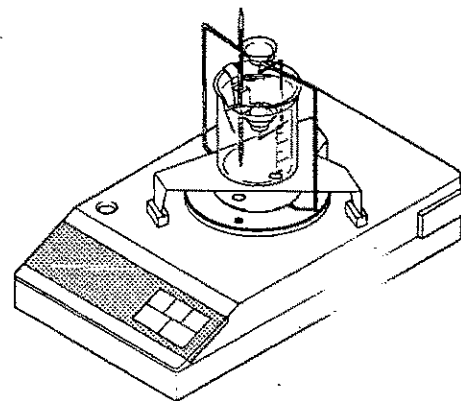
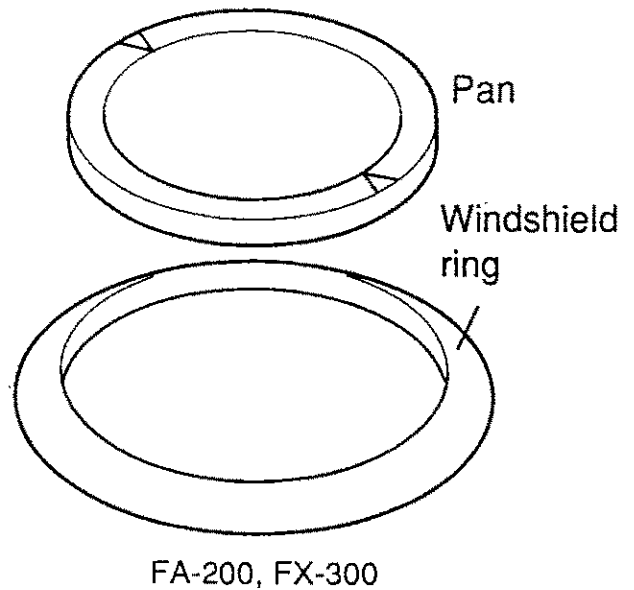

Measuring the Density of a Solid

▣ The density of a solid is obtained by averaging the measured values.

1 Press the **RE-ZERO** key to reset the displayed value to zero.

(Ex: Display of HA)

0.0000

2 Place the specimen on the upper pan and record its weight **A** in air.

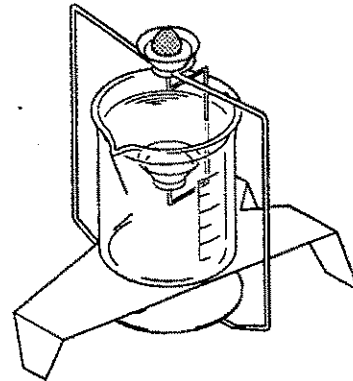

3 Press the **RE-ZERO** key to reset the displayed value to zero in the keeping **2**.

4 Place the specimen on the lower pan and record absolute value **P** in displayed value. (This is a value that is ignored minus sign of displayed value.)

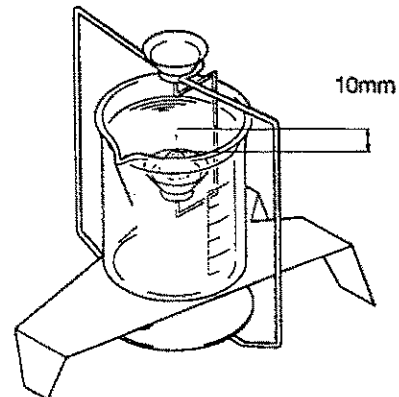

Adjust the amount of water so that the specimen is about 10 mm below the surface of the water.



Obtain the density of the water according to the temperature of water. (See Table 1-1.)

Example of Recording Sheet

Weight A in air [g]	Absolute value P in water [g]	Water temperature [°C]	$\frac{(\text{Weight A in air})}{(\text{Absolute value P in water})} \times (\text{Density of water})$	
			(g/cm ³)	(g/cm ³)
4.8102	0.5945	26	8.0651 (Calculated value)	
		Density of water [g/cm ³]		
		0.99678		



The density will be found by:

$$\rho = \frac{A}{A - B} \times \rho_0$$

ρ : Density of specimen [g/cm³]

A: Weight in air [g]

B: Weight in water [g]

ρ_0 : Density of water [g/cm³]

Table 1 Density of water

At sea level (1 atmosphere), the density of water reaches a maximum at 3.98°C. (Unit: g/cm³)

Tempera- ture	0	1	2	3	4	5	6	7	8	9
	0.	0.	0.	0.	0.	0.	0.	0.	0.	0.
0	99984	99990	99994	99996	99997	99996	99994	99990	99985	99978
10	99970	99961	99949	99938	99924	99910	99894	99877	99860	99841
20	99820	99799	99777	99754	99730	99704	99678	99651	99623	99594
30	99565	99534	99503	99470	99437	99403	99368	99333	99297	99259

5. Measuring the Density of a Liquid



▶ Assemble the kit as described in the procedure below.



Assembling the Kit

1

Follow the assembly procedure for the balance used up to the setting of the beaker stand, step 4.

2

Attach the thermometer clamp to the beaker and insert the thermometer in the thermometer clamp holes.

3

Place beaker on the beaker stand.

4

Connect the float to the float hook with a wire. The length of wire must be about 50 mm.

5

Hook the float hook on the pan stand.

6

When the value displayed on the balance becomes stable, press the **RE-ZERO** key to reset the displayed value to zero.

Preparations for measurement are now complete.

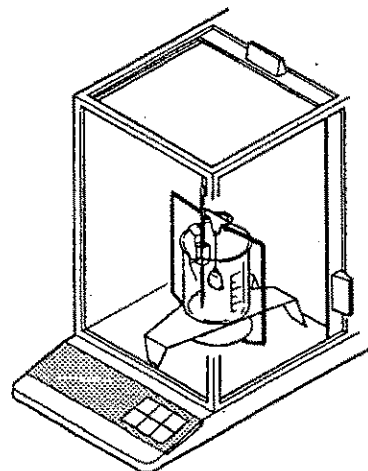
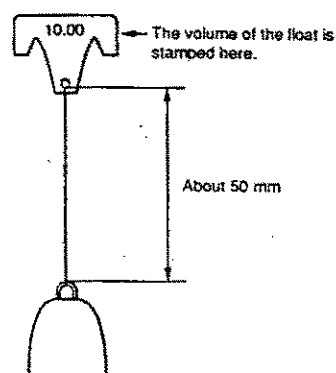

Measuring the Density of a Liquid

▣ Measure the density of a liquid by the following procedure:

1 Press the **RE-ZERO** key with the float hanging.

0.0000 g

2 Pour the liquid whose density is to be measured.

Adjust the amount of the liquid so that the float is about 10 mm below the surface of the liquid.

3 When the display becomes stable, note down the displayed value without its minus sign. (Suppose that this value is A.)

4 The density of the liquid can be found by substituting the measured value in the following equation:

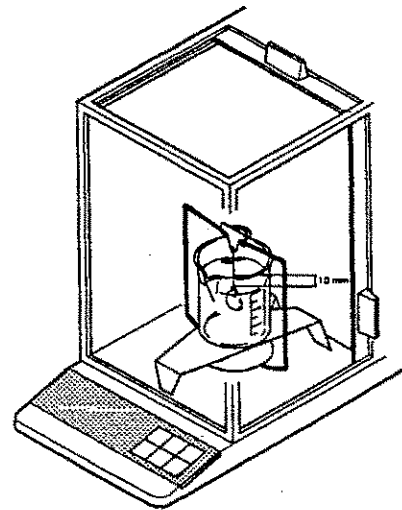

$$\rho = \frac{A}{V} + d$$

ρ : Density of liquid [g/cm³]

A: Buoyancy of float (g)

V: Volume of float (cm³)

d: Density of air [g/cm³]

Example: If the measured value (A) is 9.9704 g, the volume of the float (V) (stamped on the float hook) is 10.01 cm³, the density of air (d) is 0.001 g/cm³, the temperature indicated by the thermometer is 25°C, then we have:

$$\frac{9.9704}{10.01} + 0.001 = 0.997 \text{ g/cm}^3 \text{ (25}^\circ\text{C)}$$