

Multi-function Printer
AD-8121A

INSTRUCTION MANUAL

AND
A&D Company, Limited



This is a caution mark.



This mark informs you about the operation of the product.

Note

This manual is subject to change without notice at any time to improve the product. No part of this manual may be photocopied, reproduced, or translated into another language without the prior written consent of the A&D Company.

Product specifications are subject to change without any obligation on the part of the manufacture.

Table of Contents

FCC Rules	Page iii
Section A	
Features.....	Page A•2
Unpacking your AD-8121	Page A•3
Items Supplied	Page A•3
Handling Precautions	Page A•4
External View	Page A•5
Installing the Battery	Page A•6
Installing the Ink Ribbon Cassette and Printer Paper	Page A•7
Installing the Ink Ribbon Cassette	Page A•7
Installing the Printer Paper	Page A•9
Section B	
Control Functions	Page B•2
Keyboard	Page B•2
DIP Switches	Page B•4
Print Format	Page B•5
Data Format When Printing In Mode 1 or Mode 2.....	Page B•6
Section C	
Setup.....	Page C•2
Power Supply	Page C•3
Battery Operation.....	Page C•3
Section D	
Calendar/Clock Function.....	Page D•2
Date/Time Settings	Page D•3
Example of Date/Time Settings	Page D•5
Interval Printing and Chart Printing	Page D•6
Using theInterval Printing in the Normal Mode	Page D•6
Using the Interval Printing in the Chart Mode	Page D•8
Section E	
Statistical Calculation Mode	Page E•2

Selection of Standard Mode or Statistical Calculation Mode.....	Page E•2
Samples and Contents of Statistical Calculation Mode Printing	Page E•3

Section F

Dump Print Mode (MODE 3)	Page F•2
Printing in MODE 3	Page F•2
Online and Offline	Page F•2
Other Keys	Page F•2
Specifications.....	Page F•3
General Specifications	Page F•3
Input Specifications	Page F•3
Statistical Calculation Specifications	Page F•4

FCC Rules

Please note that this equipment generates, uses and can radiate radio frequency energy. This equipment has been tested and has been found to comply with the limits of a Class A computing device pursuant to Subject J of Part 15 of FCC rules. These rules are designed to provide reasonable protection against interference when equipment is operated in a commercial environment. If this unit is operated in a residential area it might cause some interference and under these circumstances the user would be required to take, at his own expense, whatever measures are necessary to eliminate the interference.

(FCC = Federal Communications Commission in the U.S.A.)

Section A

This section describes features of the AD-8121, the items supplied, handling precautions, external view, and how to install the batteries , printer paper and ink ribbon cassette .

Features	A•2
Unpacking Your AD-8121	A•3
Items Supplied	A•3
Handling Precautions	A•4
External View	A•5
Installing the Battery	A•6
Installing the Ink Ribbon Cassette and Printer Paper	A•7
Installing the Ink Ribbon Cassette	A•7
Installing the Printer Paper	A•9

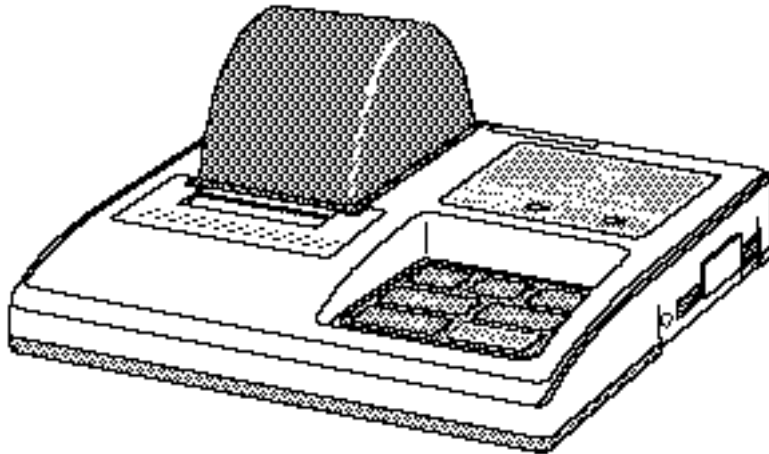

Thank you for your **A&D** purchase!

This is an Instruction Manual for the AD-8121 Multi-Function printer. The AD-8121 is a product of years of design, development, and in-field testing. It is designed to withstand harsh environmental conditions - and each printer is subjected to several levels of quality control before it leaves the factory. Every care has been taken during the manufacturing process of this printer to ensure that it will perform accurately and reliably for many years.

The AD-8121 Multi-Function Printer is mainly for use with A&D's electronic balances, counting balances, platform scales and weighing indicators. A highly reliable printer mechanism is perfect for industrial use. You can record and statistically analyze the measuring data obtained from the weighing instruments. It is easy to operate and measurements can be processed on the spot. You can operate the AD-8121 using either AC adaptor or alkaline batteries. The AD-8121 Multi-Function Printer provides fast dependable printing.

Features

- Impact dot matrix printer for superior readability
- A full range of statistical functions: Weight data, Total weight data, Counting data Total counting data, Number of operations, Standard deviation, Chart, Year, Month, Date, Hour, Minute and Second
- Interval printing with built-in Timer/Clock function: 5s, 10s, 30s, 1m, 5m, 10m, 30m
- Charting selectable to show change in weight, Interval time, Start time and Stop time
- Battery operation permits use anywhere
- Clock, calendar and pre-set functions are stored in non-volatile memory
- Compact and light weight
- Accepts RS-232C and Current loop input from A&D's Electronic Balances, Scales and Indicators
- Quiet and speedy printing

Unpacking Your AD-8121

Items Supplied

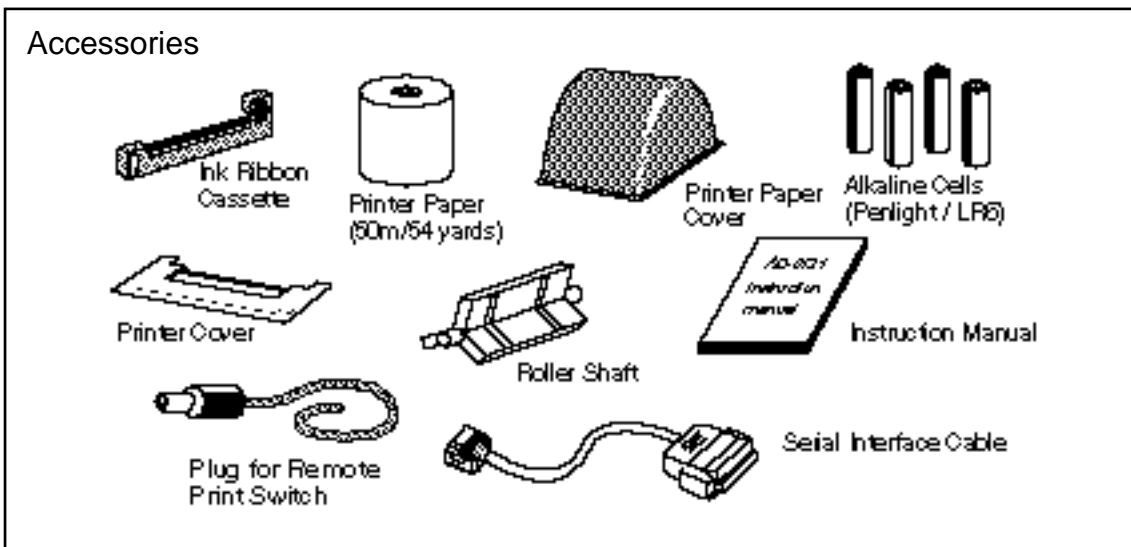
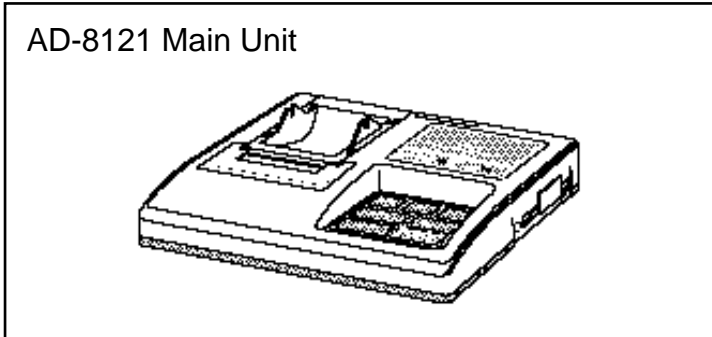

Accessories (Sold separately) & Option

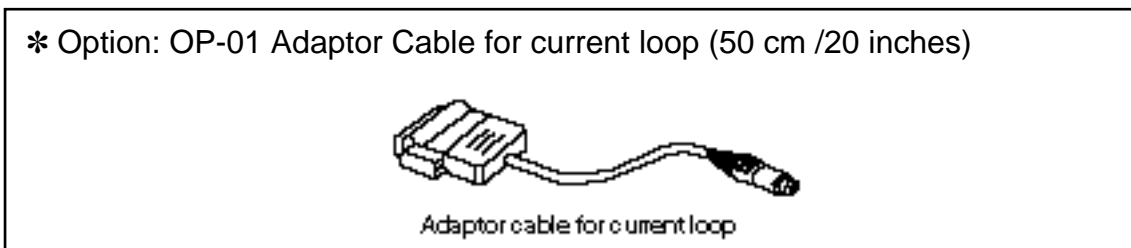
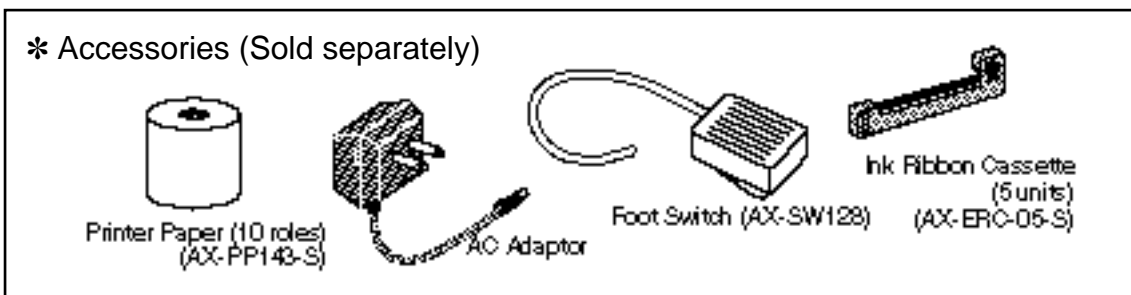

Handling precautions

In order to obtain the best possible performance from the AD-8121 instruction, read this operation manual thoroughly before operation.

Be careful when handling this unit because it is a high-precision electronic device. Note the following:

- As foreign matter in the printer section may cause the printer to jam. Use this unit where it will not be subjected to dirt, dust, water, or oil, and where it will not be subjected to direct sunlight or high temperature and high humidity.
- In order to protect the high-precision mechanism and electrical circuits of the AD-8121 from being damaged, prevent the unit from being struck or having an excessive force applied to it during its operation. Do not attempt to disassemble it.
- Be sure to connect/disconnect the plug connectors of the cables only when the power is OFF.
- Only use the specified printer paper and AC adaptor.
- Only use alkaline cells.
- Remove the batteries when not using the printer for a long time to prevent potential damage from battery leakage.
- Wait at least two seconds to switch on again after turning off the power supply switch.

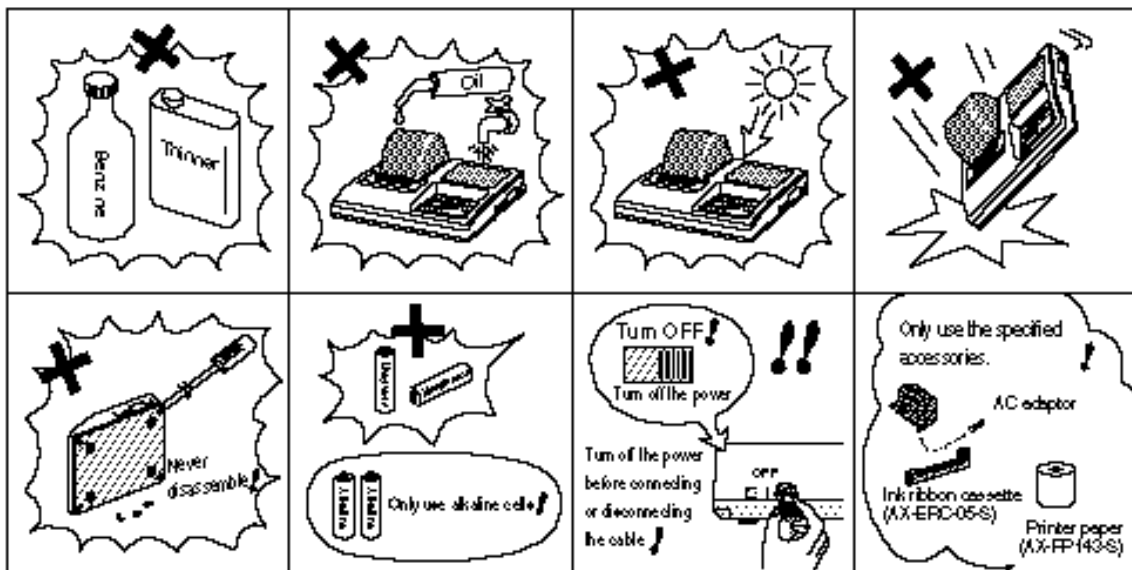

- If a malfunction occurs, refer to this manual to check the power source, switch operations, and cable connections.
When the exterior of this unit has stains, lightly wipe them off using a dry cloth or a cloth dampened in neutral detergent. Do not use an organic solvent for cleaning.

External View

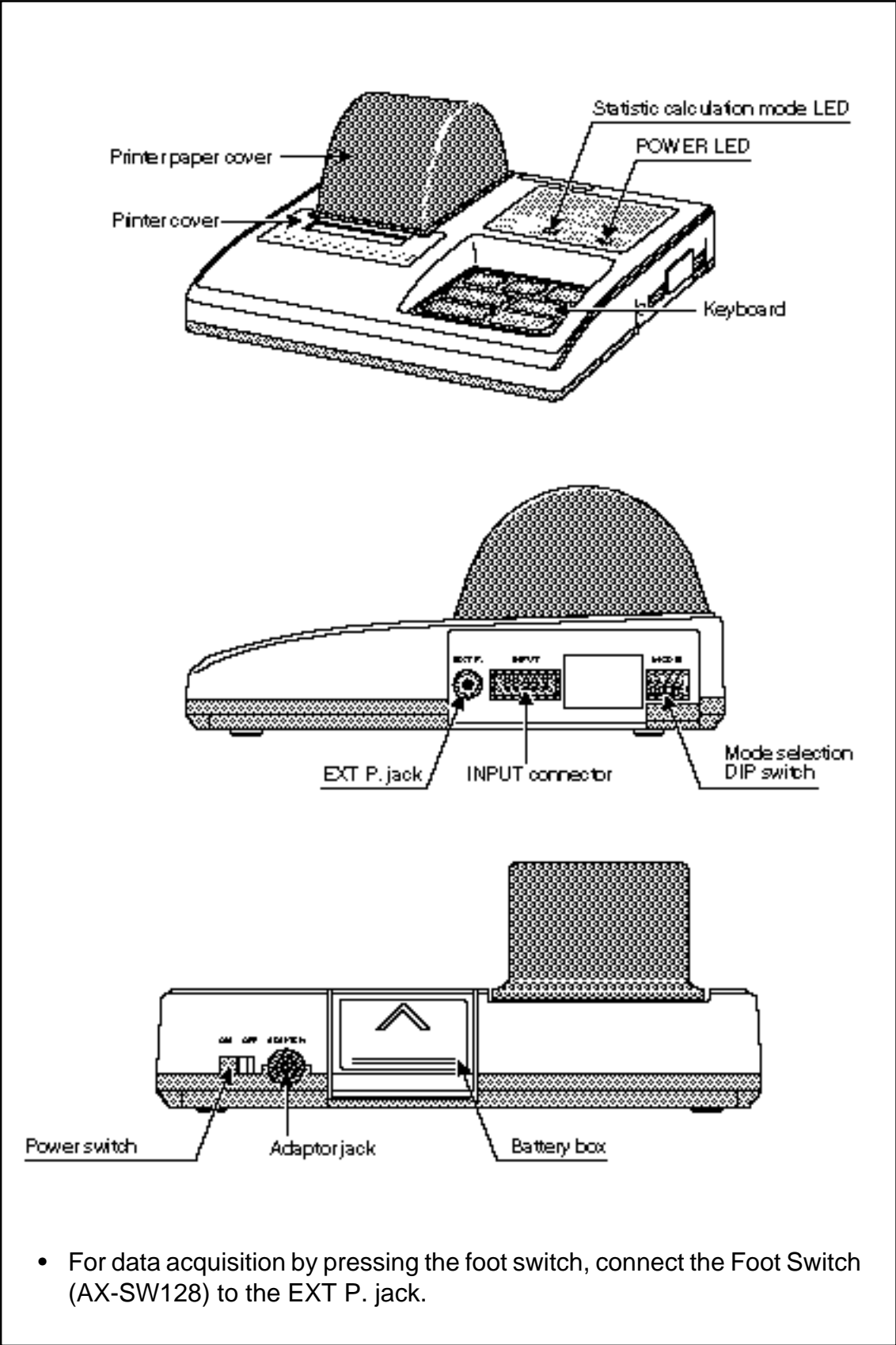

Installing the Battery

- Step 1. Open the battery box.

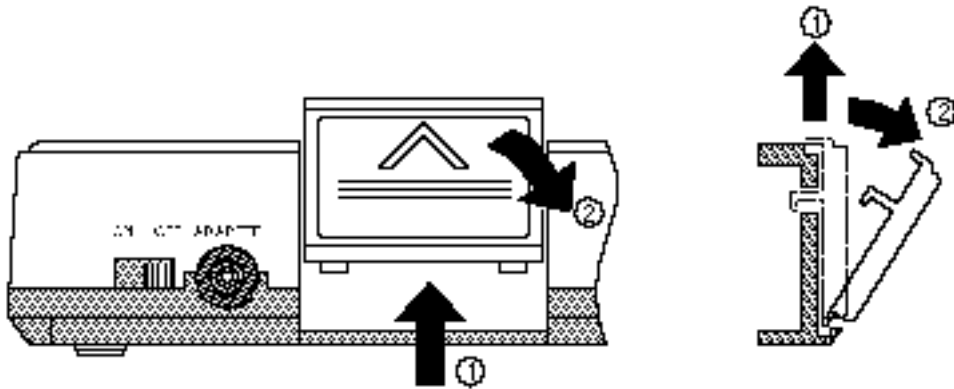

- Step 2. Install the batteries.

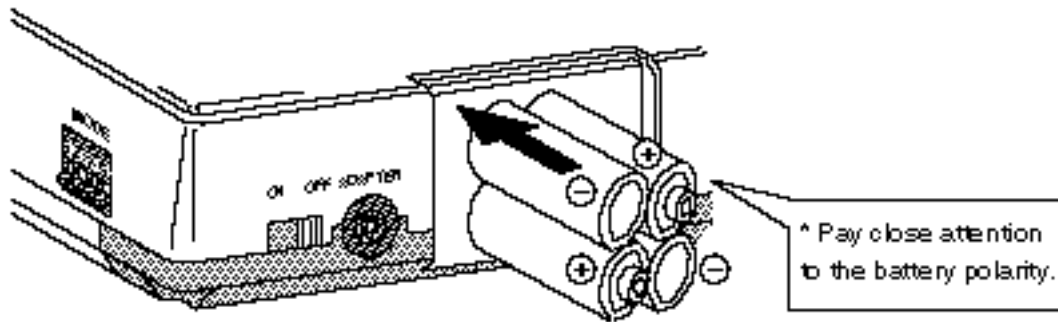

- Step 3. Close the battery box.

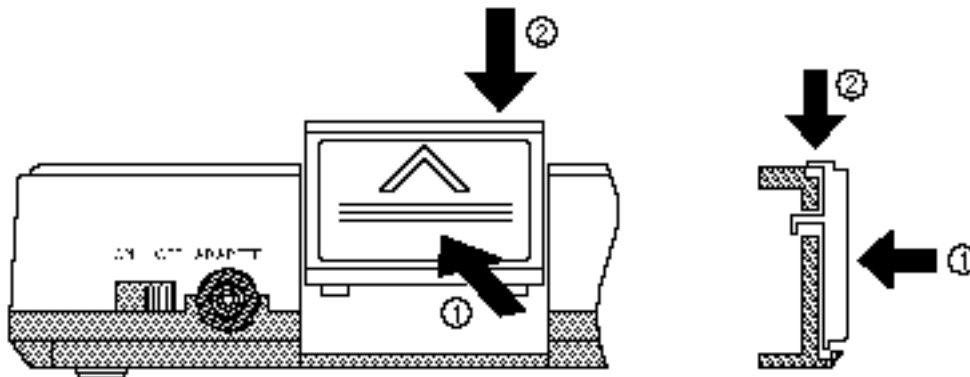

Installing the Ink Ribbon and Printer Paper

Installing the Ink Ribbon Cassette

- Step 1. Slide the printer paper cover in the direction of the arrow ①, then remove it in the upward direction.

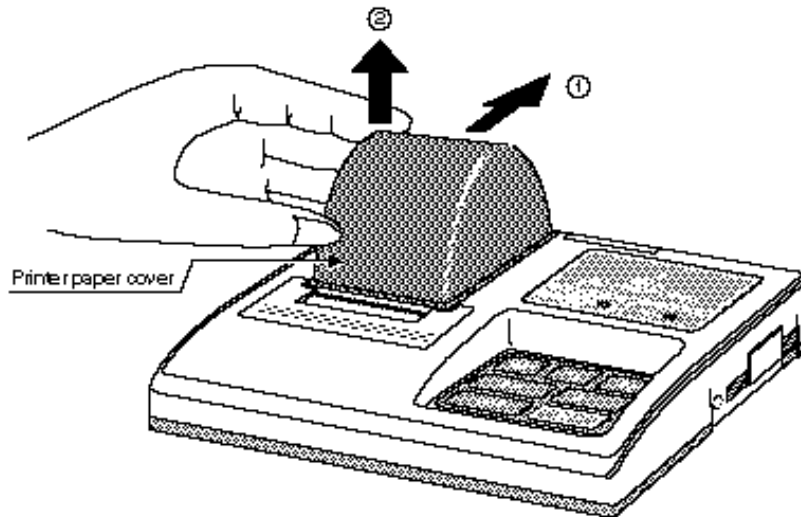

- Step 2. Remove the printer cover.

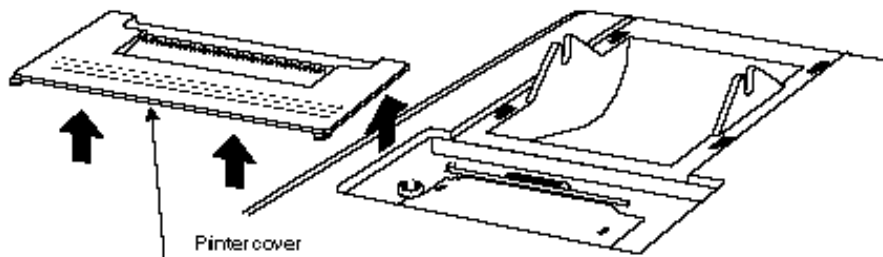

Installing the Ink Ribbon and Printer Paper

- Step 3. Installing the ink ribbon cassette supplied with your printer.

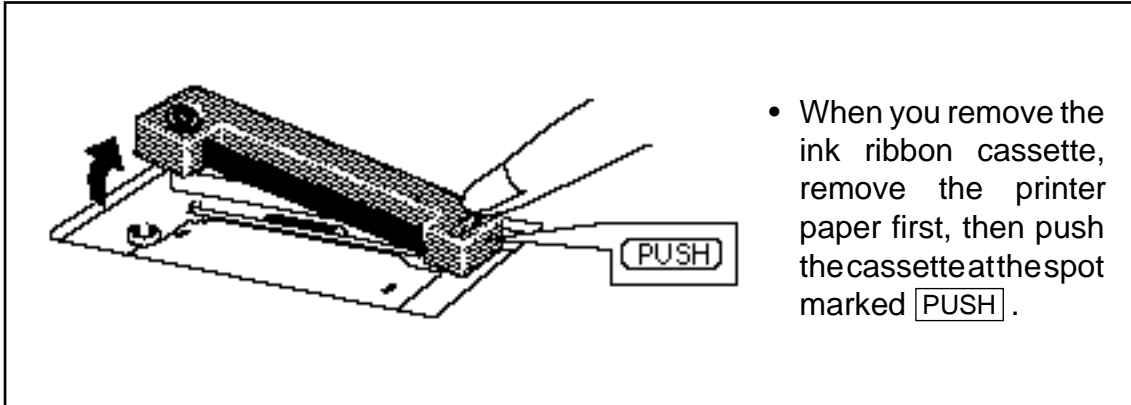
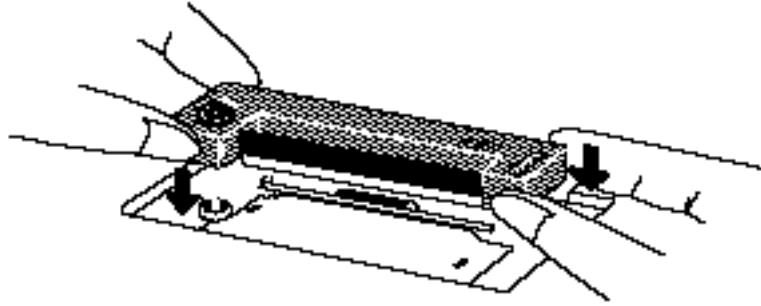

Replace the printer cover and printer paper cover in the reverse order of their removal.

Installing the Printer Paper

- Step 1. Slide the printer paper cover in the direction of the arrow ①, then remove it in the upward direction.

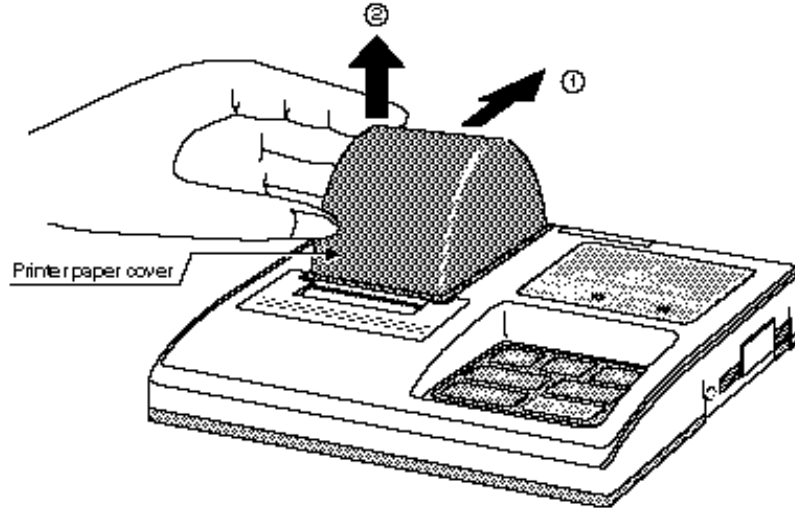

- Step 2. Remove the printer cover.

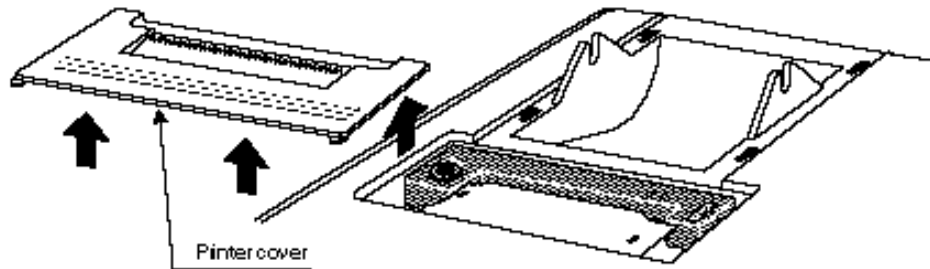

- Step 3. Cut the leading edge of the printer paper at a right angle to the feeding direction and remove wrinkles and folds from the paper if there are any.

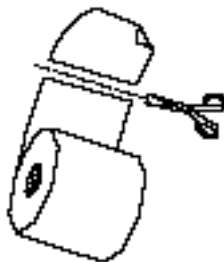

Installing the Ink Ribbon and Printer Paper

- Step 4. Turn on the power. Press the **FEED** key while lightly feeding the printer paper edge into the paper inlet until it comes out of the outlet an appropriate length. Insert the supplied shaft into the printer paper core, then set the shaft onto the bearings of the printer.

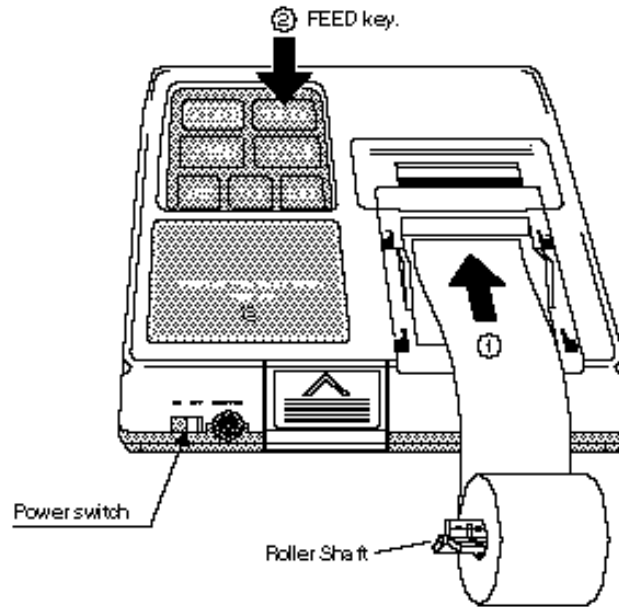

Section B



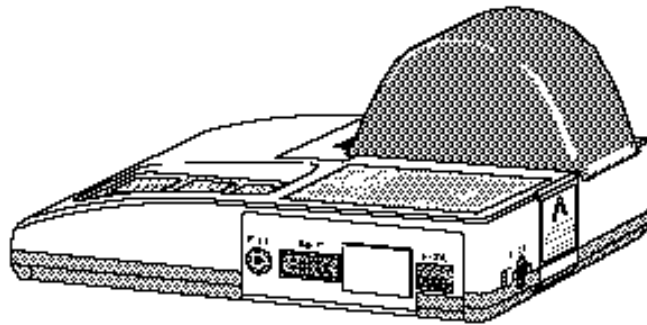

This section describes the control function, print procedure, print format and data format when printing in Mode 1 or Mode 2.



Control Functions	B•2
Keyboard	B•2
DIP Switches	B•4
Print Format	B•5
Data Format When Printing In Mode 1 or Mode 2	B•6



Control Functions

Keyboard

	<ul style="list-style-type: none"> ● DATA (Data key) Logs data from the weighing instrument and prints the data.
	<ul style="list-style-type: none"> ● FEED (Feed key) Press the FEED key to feed online. If you hold this key down, printer paper is fed continuously.
	<ul style="list-style-type: none"> ● STAT. (Statistical data selection key) Selects the statistical calculation mode for Quantity/Counting data or Weight data..
	<ul style="list-style-type: none"> ● RSLT. (Statistical calculation RESULT print key) Prints the statistical calculation results.

	<ul style="list-style-type: none"> ● CE (Clear Entry key) Clears the last data entry in the statistical calculation mode.
	<ul style="list-style-type: none"> ● CL (Clear key) Clears all the statistical data in memory in the statistical calculation mode.
	<ul style="list-style-type: none"> ● SET (Set key) Used with other keys as follows: <ul style="list-style-type: none"> ● Hold down the SET key and press the FEED key to activate the interval setting mode. ● Hold down the SET key and press the STAT. key to activate the objective digit setting for chart printing mode. ● Hold down the SET key and press the RSLT. key to activate the calendar/Clock setting mode.

DIP Switches

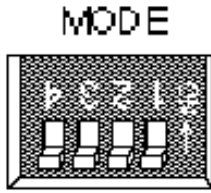

DIP Switch No.	Item	OFF	ON
NO. 1	Mode selection	MODE 1	MODE 2
NO. 2	Mode selection	MODE1/MODE2	MODE 3
NO. 3	Unstable data	No printing	Printing
NO. 4	Data input specifications	RS-232C	Current loop

DIP switch No. 1 and No. 2 (Mode selection)

The printer has three types of print modes (MODE 1, MODE 2 and MODE 3) as described below.

Table 1

	MODE 1	MODE 2	MODE 3
Printing	Prints data when data is received.	Prints data in conjunction with the DATA key or interval setting.	Prints data received as it is.
Data output mode for connected weighing instrument Key mode Auto printing	Key mode Auto printing	Stream mode	Key mode Auto printing
Interval printing	No	Yes	No
Statistical calculation	Yes	Yes	No
Others	Data on such A & D products as balances and weighing instruments can only be printed correctly when using the standard output format.		See Section F•2 "Dump Print Mode," for details.

- Use the DIP switches on the right side of the printer to select the mode.

Switch No.	4	3	2	1
MODE 1	-	-	OFF	OFF
MODE 2	-	-	OFF	ON
MODE 3	-	-	ON	-

DIP switch No. 3 (Printing unstable data)

If "No printing" is selected (with DIP switch No. 3 set OFF), unstable data will be printed as asterisks (*). (If weight data is "OVER", asterisks (*) will be printed regardless of the switch No. 3 setting.)

DIP switch No. 4 (Data input specifications)

This switch is used to select the RS-232C interface or current loop. See Section F•3, "Input Specifications," for details.

Print Format

In MODE 1 and MODE 2, the AD-8121 only prints data (on such A&D products as balances and weighing instruments) set in the standard output format.

When the standard format is used, the AD-8121 prints data as shown below.

(To print output data as it is, set DIP switch No. 2 ON to select MODE 3. See Section F•2, "Dump Print Mode," for details.)

● Printing Example in the MODE 1 or MODE 2

The printed data consists of alphanumeric characters and special symbols.

"/" is used for the calendar, as in Year/Month/Date.

":" is used for the time, as in Hour : Minute : Second. AM is used to indicate morning hours and PM (or P) is used to indicate afternoon and evening hours.

Communication error message (*C ERROR*) will be printed in case of an incorrect baud rate setting, improper cable connection, or no reception when the DATA key is pressed in MODE 2.

- Printing Example -

1:47:49 PM	01:47:49 PM
Weight	WT 123.456 g
NET weight	NT 6432.15 kg
GROSS weight	GS 9876.50 t
TARE weight	TR 200.55 g
Unit weight	UW 15.283 kg
Quantity	QT 20000 PC
Accumulated quantity	AQ 6543210 PC
Unstable data	*
Communication Error	*C ERROR*

● Error messages

If an error occurs, one of the messages listed in Table-2 will be printed.

Table-2

Error message	Probable cause
*	① Unstable or "over" data was input. ② Data which is different from the specified format was input.
C ERROR	① Improper cable connection. ② Baud rate do not match. (all should be set to 2400 bps.) ③ No power for a balance, etc.
F ERROR	① Printer malfunction due to noise.
NO DATA	① No data received from a balance, etc.

Unit

Up to three alpha characters or spaces can be used. They will be printed right-justified as in the example. The specified character string will be converted automatically as shown in Table 2 on the next page .

When there is a terminator after the numeric data, the defined character string will be printed automatically by header 1 and header 2, see Table 1.

Terminator

The printer starts printing when it receives a terminator. The terminator is fixed as CR•LF (0DH, 0AH).

Table 1

Abbreviation for the type of weight data	Header 1	Header 2	Character string printed automatically when there is no data indicating unit.
AQ	AQ	*1	□□ P C
GS	ST	GS	□□□ T
NT	ST	NT	□□ K g
QT	QT	*1	□□ P C
TR	ST	TR	□□□ T
UW	UW	*1	□□□ g
WT	ST	*1	□□□ g

”*1” indicates that you can omit header 2.

! Data except data format shown above is printed as “ * ”.

Table 2

Received data	Printing
*2 G	□□□ g
KG, Kg, kG	□□ k g
LB, Lb, lB	□□ l b
OZ, Oz	□□ o z

“ *2 ” indicates any character.

Section C

This section describes the setup and power supply.

- Setup C•2
- Power Supply C•3
 - Battery Operation C•3

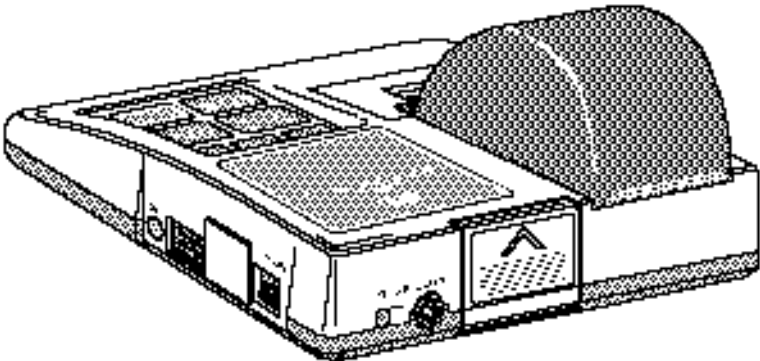

Setup



Verify that power of both the AD-8121 and the weighing instrument are turned off before connecting the units together.

1) Connection to weighing Instruments.

For data supply from an RS-232C interface, plug the 25 pin connector into the output connector of the Weighing Instrument and plug the smaller connector into the printer. For data supply by Current Loop, use the OP-01 adaptor cable and connect it to the Weighing Instrument after setting the DIP switch No. 4 ON (Current Loop).

(⚠Set the baudrate of the weighing instrument to 2400 bps.)

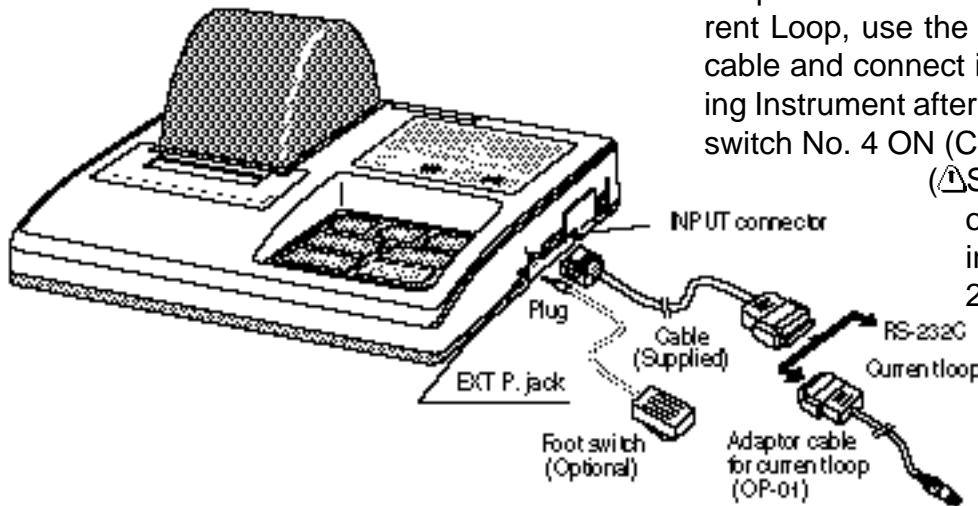

2) Connecting the specified AC Adaptor

For AC operation, connect the specified AC Adaptor to the adaptor jack on the printer.

3) Connecting the specified Foot switch (SW:128)

For data acquisition by pressing the foot switch. Connect the foot switch to the EXT. P jack on the printer.

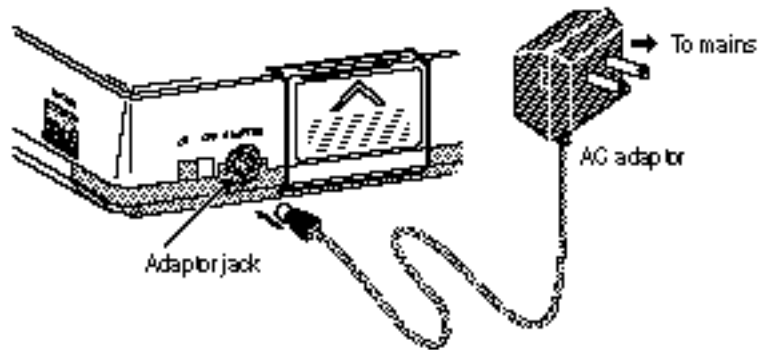

IMPORTANT

Please order the proper AC Adaptor you need according to the AC Adaptors list .

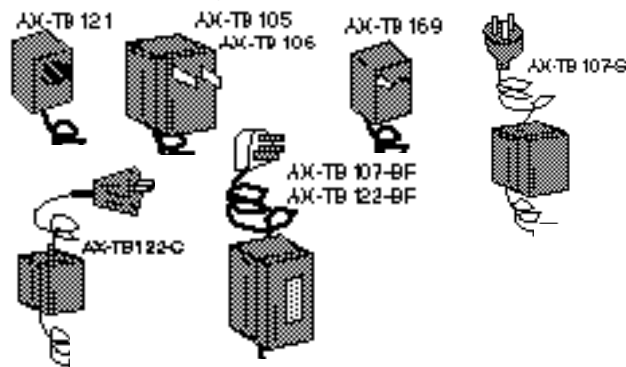

AC ADAPTORS

Model #	Voltage	Plug
AX-TB105	100	A
AX-TB106	120	A
AX-TB107	220	-
AX-TB107-BF	220	BF
AX-TB107-S	220	S
AX-TB121	220	C
AX-TB122	240	-
AX-TB122-BF	240	BF
AX-TB122-C	240	C
AX-TB169	240	S

Power Supply

The power supplied for this unit is either from the AC Adaptor or the alkaline batteries. When the AC adaptor is used while the alkaline batteries are installed, the power will be supplied from the AC adaptor.



When the power to this unit is turned off, all the statistical calculation data stored in memory will be erased. Also, if the AC adaptor is connected/disconnected while the unit is operating (disregarding whether the unit is operated by the AC adaptor or the batteries), the data accumulated may be erased.

Battery Operation

- Pay close attention to the battery polarity. (See Section. A•6 ,”Installing the Battery” for details.)
- Only use alkaline cells. Manganese cells offer inadequate power to operate the printer.
- A new battery will last about 3500 data operations under the following conditions.

Temperature conditions	25°C/77°F
Print conditions	Prints the time. Prints WT,+8888.888g every five seconds in the non-statistical calculation modes (MODE 1). Inputs data via the RS-232C interface.



When not using the printer for a long period, be sure to remove the batteries to prevent potential damage from battery leakage.

Section D

This section describes the calendar/Clock function (date/time setting) and chart printing function.

Calendar/Clock Function	D•2
Date/Time Settings	D•3
Example of Date/Time Settings	D•5
Interval Printing and Chart Printing	D•6
Using Interval Printing in the Normal Mode	D•6
Using Interval Printing in the Chart Mode	D•8

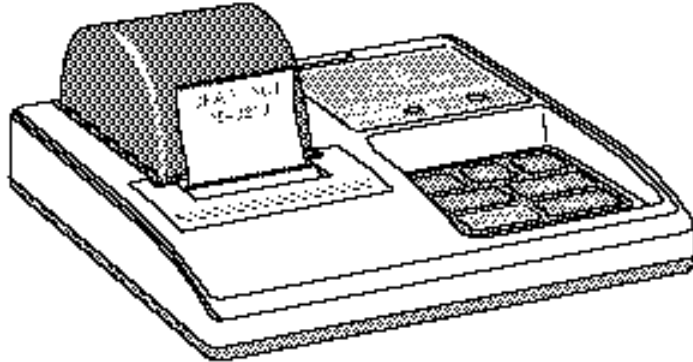

Calendar/Clock Function

The AD-8121 has a built-in Calendar/Clock backed up by a lithium battery. The Calendar/Clock continues to operate with the power turned off.

- Three kinds of calendar formats are available: Year/Month/Day, Month/Day/Year, Day/Month/Year
The time is set in 12 hours mode. (01:00:00 to 12:59:59)
- The printing or non-printing of the date and time can be selected. Otherwise, the date and time will be printed on each line independently. In the statistical calculation mode, the date is not printed.
- In MODE 3, the date and time can be printed by using control codes sent from the data source.
- Use the keys to set the date and time. The setting can be checked by printing it out.
- Leap years are not considered. Therefore, February 29th is always March 1st.

Date/Time Settings

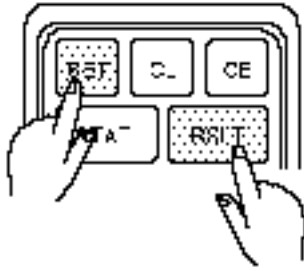

- Press the **SET** key while holding down the **RSLT.** key to enter the "Date/time" setting

- In this mode, the keys function as follows.

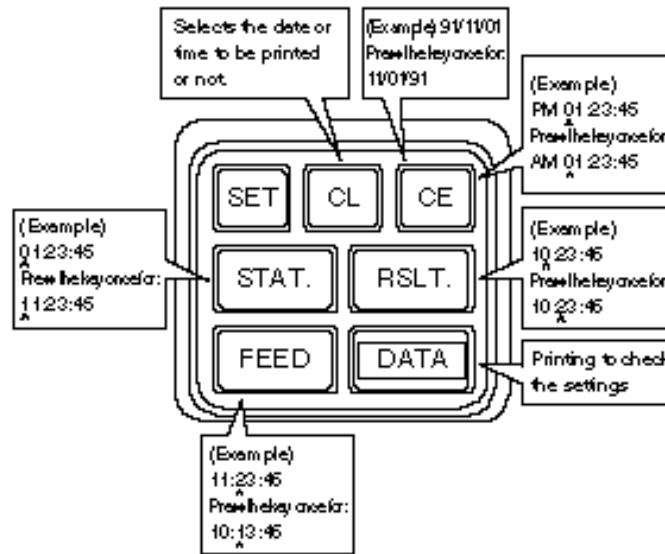

- **SET** (Set key) Enters the specified data and shifts to the next setting item.
- **CL** (Clear key) Selects the date or time for printing or no printing.
- **CE** (Cancel key) Selects the date format or AM or PM.
- **STAT.** (Stat key) Each time this key is pressed, the target digit of the setting value is incremented by one.
- **RSLT.** (Result key) Each time this key is pressed, the target digit is shifted to the right.
- **DATA** (Data key) Prints the data set for checking.
- **FEED** (Feed key) Each time this key is pressed, the target digit of the setting value is decremented by one.

- In the date/time setting mode, the date is printed using the stored date format.

The date format will be rotated through the three types as follows by pressing the **CE** key.

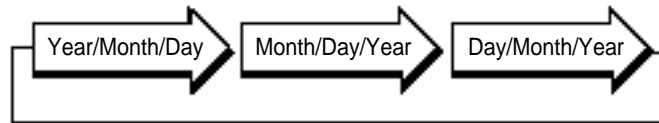

- Pressing the **CL** key while setting the date or time lets you select printing or no printing.

During "Printing" status, the green LED on the panel will light.

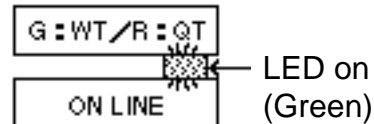

- When the **SET** key is pressed, the following information regarding printing and no printing is printed out.

"Printing" *DATE PRINT ON* *TIME PRINT ON*

"No printing" *DATE PRINT OFF* *TIME PRINT OFF*

- In the date/time setting mode, the following is printed when the SET key is pressed after the Date/time has been set.

*The following is printed after *DATE PRINT ON* or *DATE PRINT OFF*.

DATE PRINT ON

PM 01:46:46

or

DATE PRINT OFF

AM 10:16:13

*The following is printed after *TIME PRINT ON* or *TIME PRINT OFF*.

TIME PRINT ON

91/11/05 01:46P

or

TIME PRINT OFF

91/11/05 10:16A



The "second" is cut off when the setting time is changed. However, the "second" remains as it is when no setting time is changed (**RSLT.** or **FEED** is not pressed).

For example,

SET AM 09:12:26

STAT.

(Left 2 minutes)

SET 91/07/12 09:14A

The date/time setting procedure is described on the next page.

Date/Time Settings Procedure

Suppose that the date/time is set using the following example:

Date: Month/Date/Year, 11/03/91

Time: 10:05 AM

Date: No printing

Time: Printing

The data enclosed in parentheses "()" is not printed.

[SET] + [RSLT.] Start	Y/M/D	91/11/01	LED ON (Previous setting)
[CE] Date format changing	(M/D/Y	11/01/91)	
[DATA] Print checking	M/D/Y	11/01/91	
[RSLT.] Shifts ^ 1 digit to the right.	(11/01/91)		
[RSLT.] Shifts ^ 1 digit to the right.	(11/01/91)		
[RSLT.] Shifts ^ 1 digit to the right.	(11/01/91)		LED OFF
[STAT.] +1	(11/02/91)		
[STAT.] +1	(11/03/91)		
[CL] No printing the date			
[SET] Enter the date	*DATE PRINT OFF*		
	PM	01:23:45	LED ON
[CE] AM/PM selection	(AM	01:23:45)	
[STAT.] +1	(11:23:45)		
[RSLT.] Shifts ^ 1 digit to the right.	(11:23:45)		
[FEED] -1	(10:23:45)		
[RSLT.] Shifts ^ 1 digit to the right.	(10:23:45)		LED OFF (Non-statistical calculation)
[FEED] -1	(10:13:45)		
[FEED] -1	(10:03:45)		
[DATA] Print checking	AM	10:03:45	
[RSLT.] Shifts ^ 1 digit to the right.	(10:03:45)		
[STAT.] +1	(10:04:45)		
[STAT.] +1	(10:05:45)		
[SET] Date/time setting completed	*TIME PRINT ON*		
		11/03/91 10:05A	

Interval Printing and Chart Printing

The AD-8121 can print input data at constant intervals using the built-in Calendar/Clock function. Characters (Normal mode) and charts (Chart mode) can also be printed. An interval of 5, 10 or 30 seconds, and 1, 5, 10 or 30 minutes can be set. Interval printing can be done in MODE 2. Set output data print timing of the connected weighing instruments to "Stream mode".

Using the Interval Printing in the Normal Mode

- Press the **CE** key.

Now, "No chart printing" is selected. See Table-4.

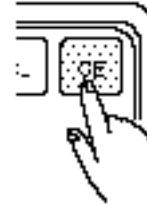

Table-4

Target digit	Key	Print
No chart printing	CE	*CHART OFF*
$10^1 - 10^0$	CL	6543210
$10^2 - 10^1$	SET	6543210
$10^3 - 10^2$	RSLT.	6543210
$10^4 - 10^3$	STAT.	6543210
$10^5 - 10^4$	DATA	6543210
$10^6 - 10^5$	FEED	6543210

(Table-4 also shows that the **CE** key selects "No chart printing", and that the **CL**, **SET**, **RSLT.**, **STAT.**, **DATA** and **FEED** keys set the target digit in the chart printing mode.)

- Interval setting

This function is used for automatically logging data from the weighing instruments at regular intervals. Hold down the **SET** key and press the **FEED** key to enter the interval setting mode.

INTERVALTIME is then printed.

The length of the interval can be determined by pressing any of the keys (see the table below for the correspondence between times and keys) to be pressed subsequently.



Table-5

Interval	Key
5 seconds	FEED
10 seconds	DATA
30 seconds	STAT.
1 minute	RSLT.
5 minutes	SET
10 minutes	CL
30 minutes	CE

(Key assignment for interval setting)

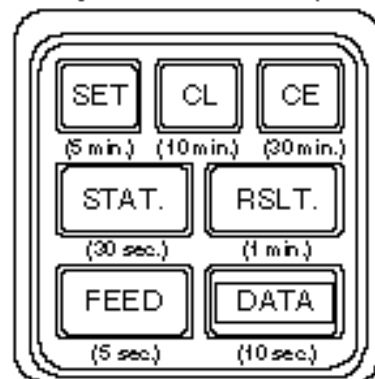

Print start command after interval setting

- When the interval is set, press the **DATA** key. Interval printing then begins.



If no data is received, the printer waits until data is received without an error message.

Exiting the interval printing mode

- Press the **SET** key to exit the interval printing.



When the interval printing is in hold status, press the **SET** key to exit this mode.

When interval printing is terminated in the normal mode (character printing)

- When interval printing is terminated in the normal mode, ***INTERVAL OFF*** is printed.



To restart interval printing, hold down the **SET** key and press the **FEED** key, then set a new interval again.

Using the Interval Printing in the Chart Mode

- Hold down the **SET** key and press the **STAT.** key.
 CHART MODE is then printed. Now the printer is in the chart mode.
 See Table-6 for the key functions used to set the target digits of chart generating.

Table-6

Target digit	Key	Print
$10^1 - 10^0$	CL	6543210 ^^
$10^2 - 10^1$	SET	6543210 ^^
$10^3 - 10^2$	RSLT.	6543210 ^^
$10^4 - 10^3$	STAT.	6543210 ^^
$10^5 - 10^4$	DATA	6543210 ^^
$10^6 - 10^5$	FEED	6543210 ^^

(A target digit setting in chart printing is assigned to each key.
 The target digits are indicated by cursor “^” in the “Print” column in Table-6.)

- Interval setting
 Hold down the **SET** key and press the **FEED** key to enter the interval setting mode.
 INTERVAL TIME is then printed.
 The length of the interval can be determined by pressing any of the keys (see the table below for the correspondence between times and keys) to be pressed subsequently.

Table-7

Interval	Key
5 seconds	FEED
10 seconds	DATA
30 seconds	STAT.
1 minute	RSLT.
5 minutes	SET
10 minutes	CL
30 minutes	CE

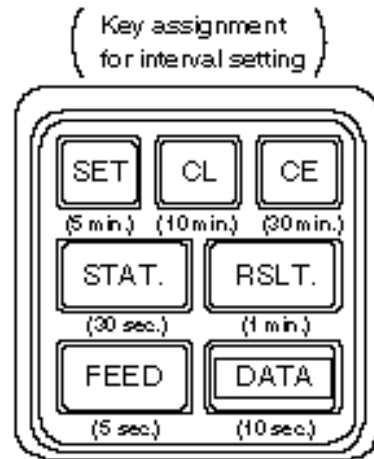

Key assignment in the chart printing mode after pressing the **SET key**

- Press the **DATA** key to start printing again in the chart mode.
- Press the **CL** or **CE** key to terminate interval printing and print ***CHART OFF***.
For print-out in the chart printing mode again, set the interval again.
- Press the **STAT.** key to exit the interval printing and print ***CHART OFF***.
After this, you will be in the statistical calculation mode.
- Press the **FEED** key to feed one line of paper in the printer.
- The **SET** key can be used with the **FEED**, **STAT.**, or **RSLT.** key to set the interval, target digits of chart printing, and date/timer.



Hold down the SET key and press the FEED key	[interval setting]
Hold down the SET key and press the STAT. key	[Corresponding digit setting for chart output]
Hold down the SET key and press the RSLT. key	[Calendar/Clock setting]

- The printer does not function when the **RSLT.** key is pressed.
- The printer outputs ***NO DATA*** when data is not received after chart printing is paused.

Section E

This section describes the statistical calculation function.

Statistical Calculation Mode	E•2
Selection of Standard Mode or Statistical Calculation Mode	E•2
Statistical Calculation Printing Mode	E•3

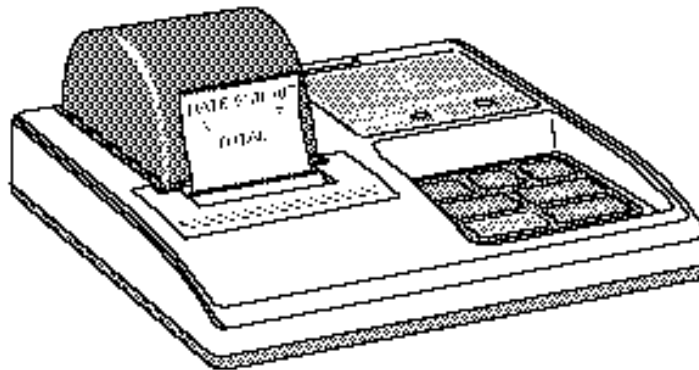

Statistical Calculation Mode



No statistical calculations will be available in MODE 3.

The AD-8121 provides the result of statistical calculation as well as printing normal weight, percentage or counting data.

Weight or quantity/counting can be selected for calculation.

Additionally, time can be printed for each sample of data.

Selection of Standard Mode or Statistical Calculation Mode

- To select the standard mode or statistical calculation mode (for weight or quantity/counting), press the **STAT.** key.
The selected LED on the printer goes on.

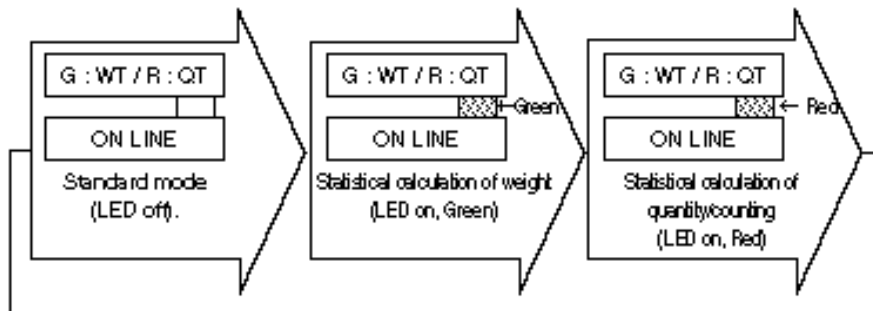

In the date print mode, the date will be printed when the printer is set from the standard mode to the weighing statistical calculation mode.



If previous data remains in memory, the mode is held even if the **STAT.** key is pressed. In this case, press the **CL** key to delete the remaining statistical data. When the data is deleted, ***CLEAR*** is printed. (See the printing example on the next page.)

Statistical Calculation Printing Mode

- If previous data remains in memory, the mode is held even if the **[STAT.]** key is pressed. In this case, press the **[CL]** key to delete the remaining statistical data. When the data is deleted, the printer will print ***CLEAR***. (1)
- When data is input, a sample number is added automatically and printed. For the "Time print" setting, the time will be printed after the sample number. (Note that the date will not be printed for each item of data.) (2)
- If an error occurs, the entry may be deleted by pressing the **[CE]** key. ***CANCEL*** is then printed. The last data is deleted from the statistical calculation. (3)
- If the position of the decimal point changes or if there is a change in the weight unit (e.g. ib, oz, ozt, g, kg, t, dwt, ct, mm, TL, GN, %, PC etc.) such data will be rejected from statistical calculations. (4)
- Press the **[RSLT.]** key to obtain the calculation results. The number of data items (N) and total (TOTAL) are then printed. (5)
For the "Time print" setting, the time will be printed on the line preceding that of the number of data items (N).
- Press the **[RSLT.]** key again to print the maximum data (MAX), minimum value (MIN), average data (\bar{X}), difference between maximum and minimum data (R), and standard deviation (). (6)
- To continue calculation, input the next data. (7)
- The maximum number of data entries possible is 999. If 1,000 data entries are made the printer will automatically make a full print-out of all the statistical information for the preceding 999 entries, clear its memory and then start again by printing the 1,000th entry as entry number one.

- Printing Example -

(1)	*CLEAR*			
(2)	NO.	1	10:09:52	A
	WT		178.632	g
			10:10:07AM	
(4)	WT		22.481	g
	NO.	2	10:10:30	A
	WT		178.668	g
	NO.	3	10:10:31	A
	WT		178.654	g
			10:10:54AM	
(4)	WT		178.6537	g
	NO.	4	10:11:09	A
	WT		178.596	g
(3)	*CANCEL*			
	NO.	4	10:11:44	A
	WT		178.640	g
	NO.	5	10:11:59	A
	WT		178.599	g
(5)	DATE	91/11/03		
	N	5		
	TOTAL	893.193 g		
(7)	NO.	6	10:12:30	A
	WT		178.623	g
	NO.	7	10:12:45	A
	WT		178.647	g
	DATE	91/11/03		
	N	7		
	TOTAL	1250.463 g		
(6)	MAX	178.663 g		
	MIN	178.599 g		
	\bar{X}	178.638 g		
		0.0224 g		
	R	0.069 g		

Section F

This section describes dump printing and the AD-8121 specifications.

Dump Print Mode (MODE 3)	F•2
Printing in MODE 3	F•2
On-line and Off-line	F•2
Other Keys	F•2
Specifications	F•3
General Specifications	F•3
Input Specifications	F•3
Statistical Calculation Specifications	F•4

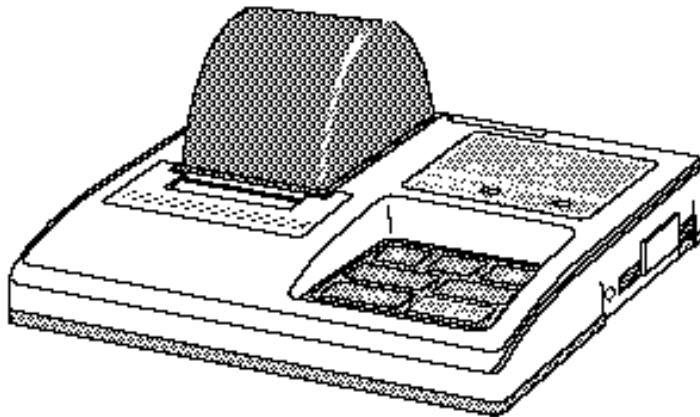

Dump Print Mode (MODE 3)

Printing in MODE 3



Set DIP switch No. 2 ON.

- In MODE 3, the received data is printed as it is, no statistical calculations will be available in MODE 3.

The data consists of ASCII code 20 (H) to 7F (H) and characters shown to the right can be printed. (Comma (,) and 2C (H) cannot be printed-out.)

```

**      MULTI      **
**      FUNCTION   **
**      PRINTER    **
**      AD-8121    **
**      CHARACTER  **
    
```

The specified code is processed as follows.

1B (H) 44 (H) Prints the date.

1B (H) 54 (H) Prints the time.

Up to 16 characters can be printed per line. For 17 or more characters, a line is generated after 16 characters are printed.

Set an interval of 1.1 seconds or more between the first sample of data (consisting of one line) and the next sample of data.

On-line and Off-line

In the dump print mode (MODE 3), the received data is printed as it is. The printer can also be set for no printing even when data is received.

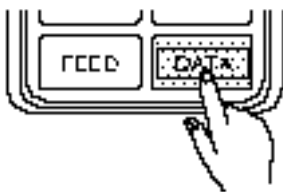

The green LED on the printer goes on or off, accordingly.

- Printing and no printing are alternately selected each time the **DATA** key is pressed in MODE 3. "Online" denotes printable status when data is received, and "offline" denotes non-printable status when data is received.

Table-8

MODE 3 (DIP switch No. 2 ON)		
<ul style="list-style-type: none"> • Online LED on, green 	Prints received data.	<p>G = WT/R = QT ON LINE ← LED on (Green)</p>
<ul style="list-style-type: none"> • Offline LED off 	Does not print received data.	<p>G = WT/R = QT ON LINE ← LED off</p>

Other Keys

- In MODE 3, paper can be fed by pressing the **FEED** or **DATA** key. All keys except the **FEED** and the **DATA** keys are disabled. (The EXT.P key functions the same as the **DATA** key.)

Specifications

General Specifications

Model	AD-8121
Printer Type	Mechanical dot impact printer
Character Size	5 x 7 dots 2.5 (H) x 1.8 (W) mm 0.1(H) x 0.7 (W) inches
Printing Speed	1 line/sec.
Paper Feed Speed	1 line/sec.
Number of Character	16 characters/line
Power Supply	AC/DC Adaptor (9V 700mA)/ Alkaline batteries (Approx. 7.000 lines)
Lithium Battery Life	Approx. 5 years
Printer Head Life	Approx. 500,000 lines
Operating Temperature Range	0°C to 40°C / 14°F to 104°F
Operating Humidity Range	80%RH or less (No condensation)
Storage TemperatureRange	-10°C to 50°C / 14°F to 122°F
Data Input Section	RS-232C or current loop
External Control	Printing only
Dimensions	180 (W) x 160 (D) x 80.5 (H) mm 7.1 (W) x 6.3 (D) x 3.2 (H) inches
Weight	Approx. 420g / 0.92lb (Without paper or batteries)

Recording Paper	PP143
Paper Quality	Fine
Paper Thickness	0.07 mm
Paper Width	44.5 mm
Length	Approx. 50 m
M a x i m u m RolledDiameter	ø 65mm

Input Specifications

Communication Method	RS-232C or current loop
Baud Rate	2400 bps
Data Bit	7 bits
Parity Bit	1 bit (EVEN)
Stop Bit	1 bit
Code	ASCII
Input Connector	XG4C-T0003 (Omron)

Pin No	Signal
3	RXD (Received data)
4	To pin 5
5	To pin 4
7	SG (Signal ground)
9	Current loop
10	Current loop

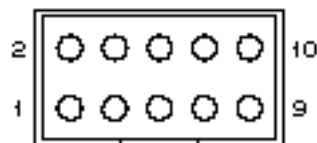

AD-8121 INPUT CONNECTOR

Statistical Calculation Specifications

- N : Number of data (999 samples Max.)
- TOTAL : Cumulative total
- MAX : Maximum data
- MIN : Minimum data
- \bar{X} : Average data
- σ : Standard deviation
- R : Range of data (Difference between maximum and minimum data)

$$\left(\sigma = \sqrt{\frac{N \cdot \sum (x_i)^2 - (\sum x_i)^2}{N(N-1)}} \right)$$

- Specifications are subject to change for improvement without notice.

[Blank page]



A&D Company, Limited

3-23-14 Higashi-Ikebukuro, Toshima-ku, Tokyo 170-0013 JAPAN
Telephone: [81] (3) 5391-6132 Fax: [81] (3) 5391-6148

A&D ENGINEERING, INC.

1555, McCandless Drive, Milpitas, CA. 95035 U.S.A.
Telephone: [1] (408) 263-5333 Fax: [1] (408)263-0119

A&D INSTRUMENTS LTD.

Unit 24/26 Blacklands Way, Abingdon Business Park, Abingdon, Oxon OX14 1DY United Kingdom
Telephone: [44] (1235) 550420 Fax: [44] (1235) 550485

<German Scales Office>

Berner Straße 64, 60437 Frankfurt/Main 50 GERMANY
Telephone: [49] (69) 507-1017 Fax:[49] (69) 507-2054

A&D MERCURY PTY. LTD.

32 Dew Street, Thebarton, South Australia 5031 AUSTRALIA
Telephone: [61] (8) 8352-3033 Fax: [61] (8) 8352-7409

A&D KOREA Limited

8th Floor, Manhattan Bldg. 36-2 Yoido-dong, Youngdeungpo-ku, Seoul, KOREA
Telephone: [82] (2) 780-4101 Fax: [82] (2) 782-4280