

# EK-H SERIES

## INSTRUCTION MANUAL

---

### Compact Balances

EK-400H  
EK-600H  
EK-4000H  
EK-6000H

© 1998 A&D COMPANY LTD. ALL RIGHTS RESERVED

No part of this publication may be reproduced, transmitted, transcribed, or translated into any language in any form by any means without the written permission of A&D Company Ltd.

The contents of this manual and the specifications of the instrument covered by this manual are subject to change for improvement without notice.

## **COMPLIANCE WITH FCC RULES**

Please note that this equipment generates, uses and can radiate radio frequency energy. This equipment has been tested and has been found to comply with the limits of a Class A computing device pursuant to Subpart J of Part 15 of FCC rules. These rules are designed to provide reasonable protection against interference when equipment is operated in a commercial environment. If this unit is operated in a residential area it might cause some interference and under these circumstances the user would be required to take, at his own expense, whatever measures are necessary to eliminate the interference.

(FCC = Federal Communications Commission in the U.S.A.)

### **Note**

Under some ambient electromagnetic conditions, this equipment may be affected by the electromagnetic interference.

This is hazard alert mark.

---

# Contents

---

<b>1. INTRODUCTION .....</b>	<b>1</b>
<b>2. UNPACKING .....</b>	<b>1</b>
<b>3. PART NAMES AND FUNCTIONS .....</b>	<b>2</b>
<b>4. SETTING UP .....</b>	<b>3</b>
4-1. Setting up your balance .....	3
4-2. Power source .....	3
<b>5. OPERATION .....</b>	<b>4</b>
5-1. Turning the power ON and OFF .....	4
5-2. Turning the display ON and OFF .....	4
5-3. Units .....	5
5-4. Selecting a weighing unit .....	6
5-5. Basic operation .....	6
5-6. Counting mode (PCS) .....	7
5-7. Percent mode (%) .....	8
5-8. Hold function .....	9
<b>6. CALIBRATION .....</b>	<b>11</b>
6-1. Calibration using a weight .....	11
<b>7. SETTING RESPONSE CONDITION .....</b>	<b>13</b>
<b>8. FUNCTIONS .....</b>	<b>14</b>
8-1. Key operation .....	14
8-2. Entering the function setting mode .....	14
8-3. Setting example .....	15
8-4. Storing a weighing unit .....	16
8-5. Function list .....	17
8-6. Initial settings .....	19

8-7. To permit or prohibit key operation .....	20
<b>9. COMPARATOR .....</b>	<b>21</b>
9-1. Setting example 1 .....	21
9-2. Setting example 2 .....	23
9-3. Setting example 3 .....	24
<b>10. ID NUMBER AND GLP .....</b>	<b>26</b>
10-1. Setting the ID number .....	26
10-2. Calibration test .....	27
10-3. Output examples .....	29
<b>11. OPTIONS .....</b>	<b>30</b>
<b>12. MAINTENANCE .....</b>	<b>31</b>
12-1. Notes on maintenance .....	31
12-2. Error codes .....	31
<b>13. SPECIFICATIONS .....</b>	<b>32</b>

## 1. INTRODUCTION

This manual describes how this balance works and how to get the most out of it in terms of performance.

The EK-H series includes the EK-400H, EK-600H, EK-4000H, and EK-6000H.

EK series balances have the following features:

- Comparator indicators to classify a weighing value
- Good Laboratory Practices (GLP) data output using a serial interface.
- With the optional NiCd battery pack (OP-09H), the balance can be used for cordless operation. (Be sure to charge the battery pack before using it for the first time.)
- A hold function to display the average reading, enabling measuring items difficult to read the weight value such as an animal that is moving.

## 2. UNPACKING

When unpacking, check whether all the following items are included:

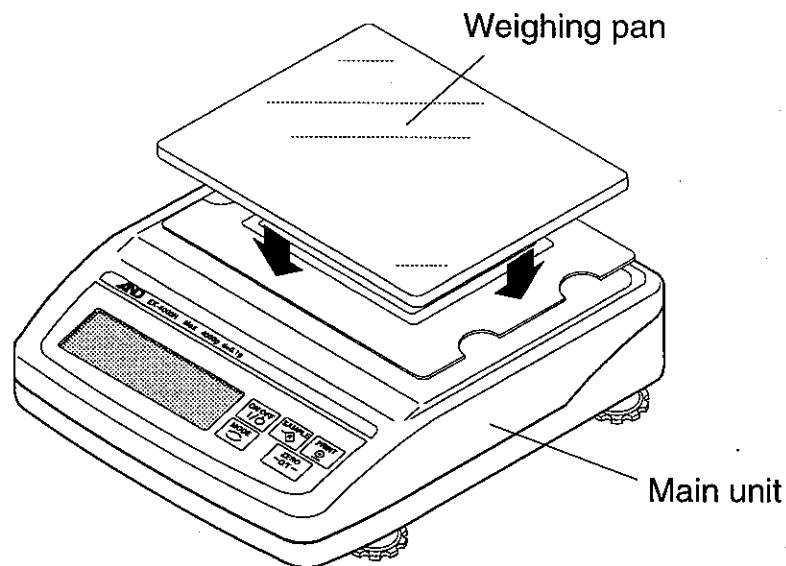

AC adapter

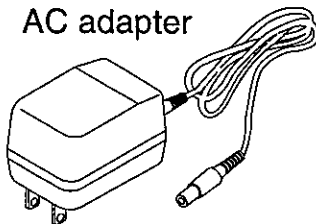

**Please confirm that the AC adapter type is correct for your local voltage and receptacle type.**

Instruction manual

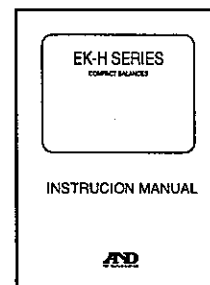

## 3. PART NAMES AND FUNCTIONS

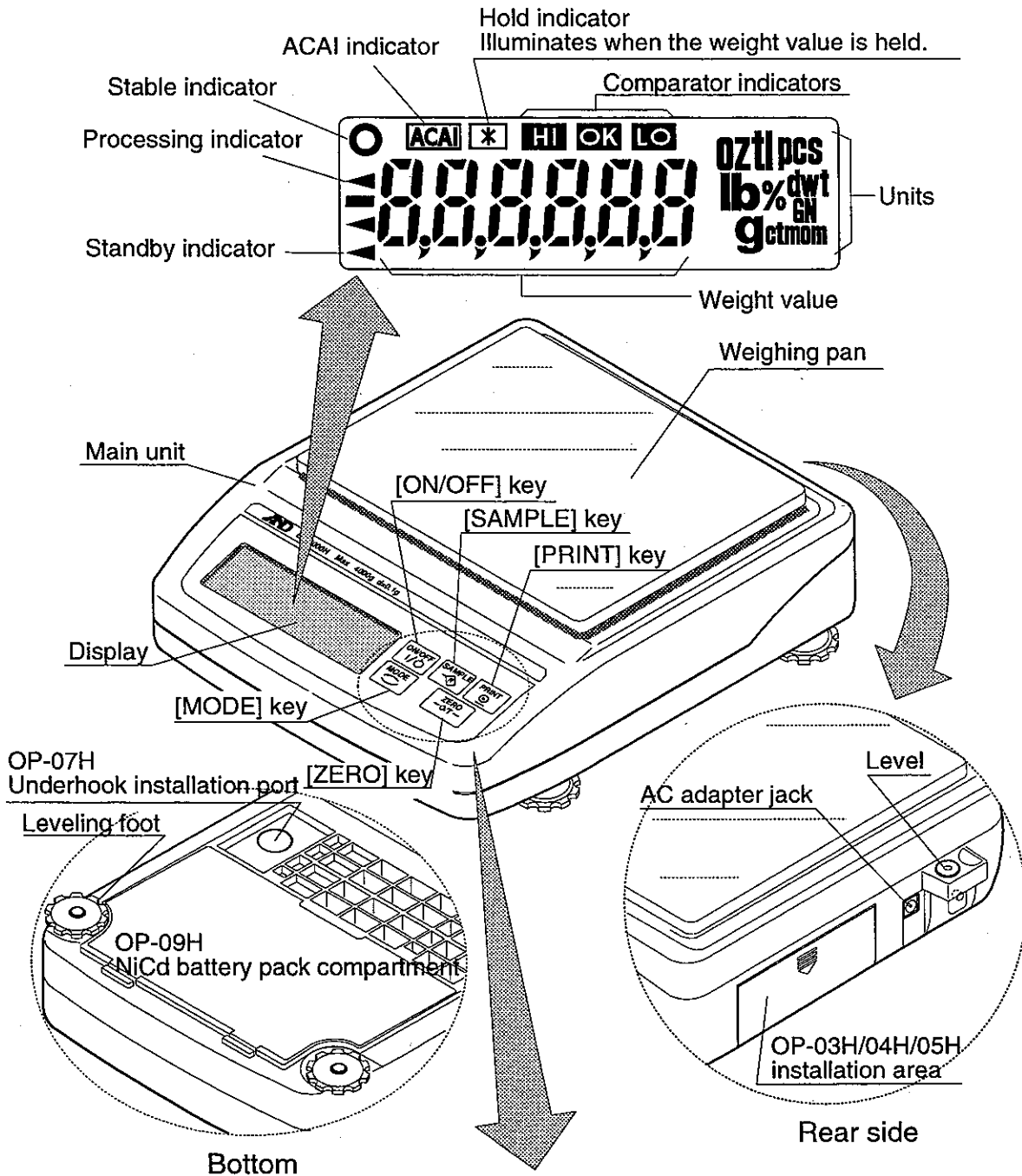

<b>ON/OFF</b> I/O	Turns on or off the display.	<b>PRINT</b> ⊙	Outputs the weight value to a printer.
<b>SAMPLE</b> -R	Held down to enter the function setting mode. g mode: Turns on or off the least digit. PCS mode: Enters the sample unit weight storing mode. % mode: Enters the 100% weight storing mode.	<b>MODE</b> ↻	Switches the weighing unit (the weighing mode).
		<b>ZERO</b> →0/T←	Clears the display to zero.

---

## 4. SETTING UP

---

### 4-1. Setting up your balance

1. Place the weighing pan on the main unit as shown on the previous page.
2. Adjust the level of the balance using the leveling feet. Use the spirit level to confirm.
3. Calibrate the balance before use.  
(Refer to "6. Calibration")

#### Balance location

To measure correctly, to keep the balance in good conditions, and to prevent hazards, observe the followings:

- Do not install the balance in locations that are subject to dust, breeze, vibration, great temperature fluctuations, condensation or that may have a magnetic field.
- Do not install the balance on a surface that is soft or that may cause the balance level to shift.
- Do not install the balance in direct sunlight.
- Do not install the balance near heaters or air conditioners.
- Do not use an unstable AC power source.



***Do not install the balance in a place where combustible or corrosive gases may exist.***

### 4-2. Power source

For the power source, the AC adapter or the NiCd battery pack (OP-09H: Option, sold separately) is available.

#### When using the AC adapter

Use a stable power source. To use the AC adapter, insert the AC adapter plug into the AC adapter jack on the EK-H.

#### When using the NiCd battery pack

Insert the NiCd battery pack into the EK-H battery pack compartment. The balance can be used continuously for 8 hours using the battery pack. (With other options installed, the time will be approximately 6 hours. The time may vary with the method of use.) For details on using the battery pack, refer to the options manual.

***If "Lb" is displayed when using the battery pack, immediately stop using it, and recharge the battery pack or use the AC adapter.***

## 5. OPERATION

### 5-1. Turning the power ON and OFF

Using the AC adapter, connect the balance to the power source. The power ON test display appears for a few seconds. Then the display will disappear and the balance will be in "standby" state. Even if nothing is displayed, the power is connected. Warm up for a few minutes. Place nothing on the pan at this stage.



Standby indicator

### 5-2. Turning the display ON and OFF

1. Press the **ON/OFF** key to turn the display ON.



All the display symbols illuminate as shown above.  
(About units: Only the units available illuminate.)

**Note:**

Pressing the **ON/OFF** key in the display ON condition will clear all the display symbols (standby mode, if the power is still connected).

## 5-3. Units

The most common unit of weight used around the world is grams, but there is often a need to shift to an alternative unit specific to the country where the balance is used or to select modes such as counting or percent.

The units and the order they appear in the display are as follows:

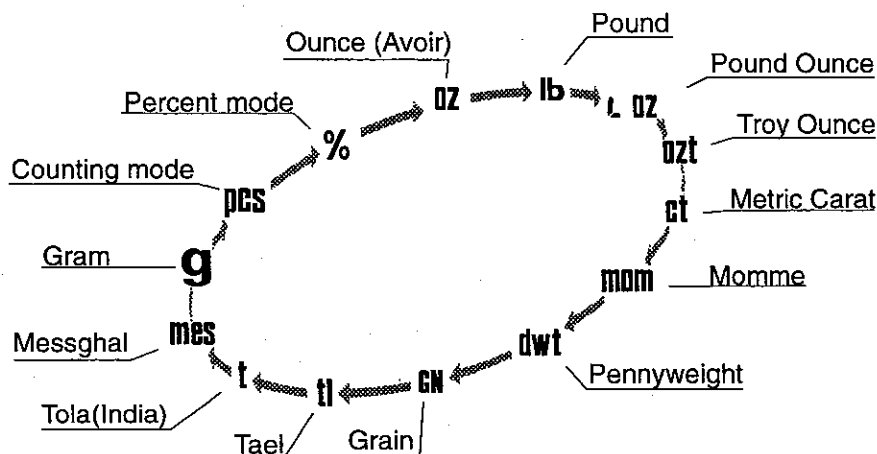

Among the units, those available for the user have been set at the factory before shipping.

The unit can be selected in the function setting mode. The order the units available appear is the same as above, while skipping the units that are not available.

**Note** *It is possible to store only the units that will be actually used from the units available. For details, refer to "8-4. Storing a weighing unit".*

### Conversion table

Abbrev.	Name	Conversion
oz	Ounce (Avoir)	28.349523125 g
lb	Pound(UK)	453.59237 g
lb/oz	Pound Ounce	28.349523125 g (16 oz = 1 lb)
ozt	Troy Ounce	31.1034768 g
ct	Metric Carat	0.2 g
mom	momme	3.75 g
dwt	Pennyweight	1.55517384 g
GN	Grain (UK)	0.06479891 g
TL	Tael (HK general, Sing.)	37.7994 g
TL	Tael (HK, jewelry)	37.429 g
TL	Tael (Taiwan)	37.5 g
TL	Tael (China)	31.25 g
t	Tola (India)	11.6638038 g
mes	Messghal	4.6875 g

## 5-4. Selecting a weighing unit

Select a unit as follows:

1. Press the **MODE** key several items to select a unit.

The following sections describe three common units: g (weight displaying mode=gram mode), PCS (counting mode), and % (percent mode)



Each pressing switches the units available in the order described on the previous page.



## 5-5. Basic operation

1. Select a weighing unit.  
(Refer to "5-4. Selecting a weighing unit".)

2. Place a "tare" on the weighing pan, and press the **ZERO** key. The balance displays **0.0 g**.

**Tare:** A container placed on the pan to hold an object, but not to be included in the weight.

3. Place the object to be weighed in the container.  
Wait for the stable indicator  to be displayed and read the value.

4. Remove the object from the pan.

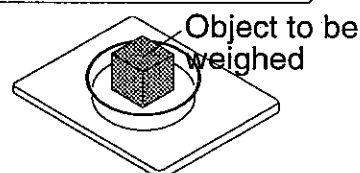
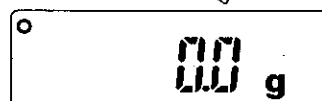
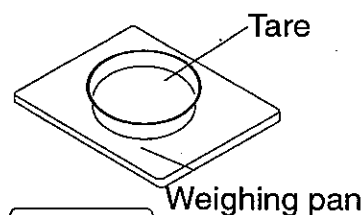

**With g mode:**

Press the **SAMPLE** key to make the least digit blank.

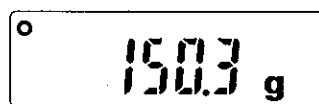

## Precautions during operation

- Make sure that the stable indicator is on whenever reading or storing a value.
- Do not press keys with a sharp instrument such as a pencil.
- Do not apply a shock or a load on the pan that is beyond the weighing range.
- Keep the balance interior free from foreign objects such as dust or liquid.
- Calibrate the balance periodically to keep weighing accuracy.  
(Refer to "6. Calibration".)

## 5-6. Counting mode (PCS)

Determines the number of objects in a sample. Calculates the reading using the basic sample unit weight to determine how many pieces are contained.

### Selecting the counting mode

1. Press the **MODE** key to select **PCS**.  
( pcs : pieces)

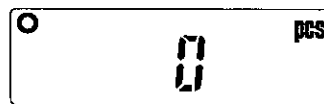

### Storing the sample unit weight

2. Press the **SAMPLE** key to enter the sample unit weight storing mode.
3. To select the number of samples, press the **SAMPLE** key. It may be set to 10, 25, 50 or 100.
4. Place a tare container on the weighing pan, and press the **ZERO** key. The number specified in step 3 appears.
5. Place the number of samples specified on the pan. In this example, 25 pieces.
6. Press the **PRINT** key to calculate and store the unit weight. Remove the sample. The balance is set to count objects with this unit weight.

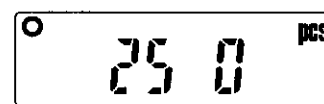
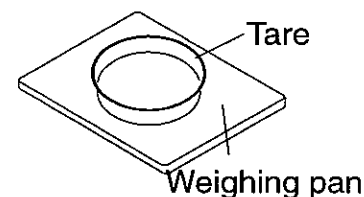
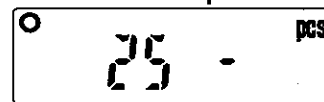
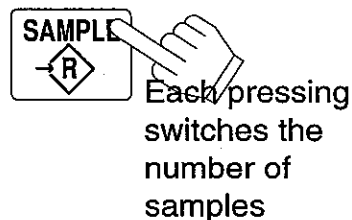
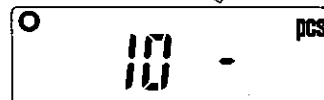
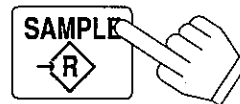

### Counting the objects

7. Place the objects to be counted on the pan.

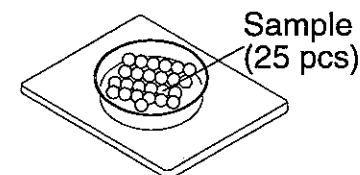

### Counting mode using the ACAI function

ACAI™ (Automatic Counting Accuracy Improvement) is a function that improves the accuracy of the unit weight by increasing the number of samples as the counting process proceeds.

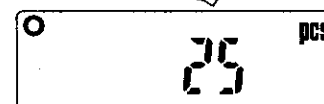
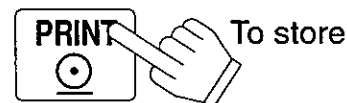

Has stored

8. If a few more samples are added, the ACAI indicator illuminates. (To prevent an error, add three or more. The ACAI indicator will not illuminate if overloaded.)

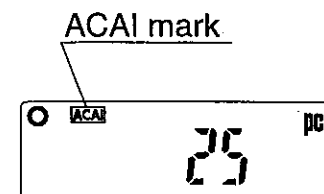

9. The balance re-calculates the unit weight while the ACAI indicator is blinking. Do not touch the balance or samples on the pan until the ACAI indicator turns off.
10. Counting accuracy is improved when the ACAI indicator turns off. Each time the above operation is performed, a more accurate unit weight will be obtained. There is no definite upper limit of ACAI range for the number of samples exceeding 100. Try to add the same number of samples as displayed.

## 5-7. Percent mode (%)

Displays the weighing value in percentage compared to the reference (100%) weight. An allowable range of a certain percentage can be set for comparison.

### Selecting the percent mode

1. Press the **MODE** key to select **%**. (% : percent)

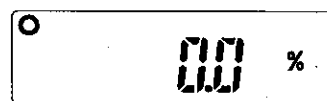

### Storing the reference (100%) weight

2. Press the **SAMPLE** key to enter the reference weight storing mode.
3. Press the **ZERO** key to display **100 0 %**.
4. Place the sample to be set as the reference weight on the pan.
5. Press the **PRINT** key to store the reference weight. Remove the sample.

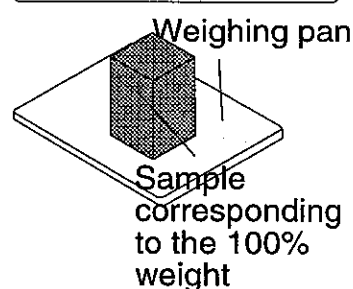
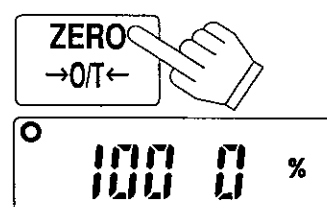
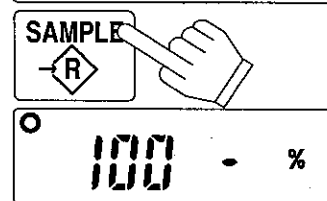

### Reading the percentage

6. Place the object to be compared to the reference weight on the pan. The displayed percentage is based on 100% of the reference weight.

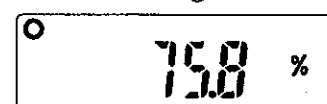
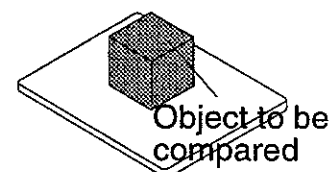
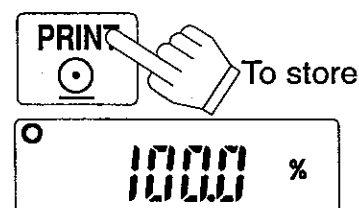

**Note:** *The number of decimal places varies with the reference weight.*

## 5-8. Hold function

Use the hold function to weigh small living animals. The balance is allowed to stabilize for a fixed period of time, then the Hold indicator () comes on and the average sample weight of the moving object is displayed.

**Note:** Select 1 for the function setting, *bR5FnC.HoLd*.  
Set the weighing unit to one other than the counting mode.

### Hold function Conditions:



After setting the display to zero, the hold function is only activated if the display changes by at least the amounts shown in the following table. If the weight is less than the amount given below, the balance will remain in the normal weighing mode.

Initial Range	Model
0.50 g	EK-600H, EK-400H
5.0 g	EK-6000H, EK-4000H

### Hold function Averaging Time:

This function corresponds to the function *bR5FnC, L0nd* in the following way:

*bR5FnC* Environment, Display

<i>L0nd</i> Response / Environment	Averaging Time		Better weighing conditions faster weighing response 	Worse weighing conditions slower weighing response 
	0	2 sec		
	*1	4 sec		
2	8 sec			

\* factory setting

### Hold function Stabilization range:

This function corresponds to the internal setting *bR5FnC, St-b* in the following way:

*bR5FnC* Environment, Display

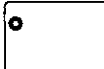
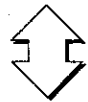
<i>St-b</i> Stability band width	 This indicator is displayed when the weighing data is averaged within the range set below.		
	0	Stable when within $\pm 6.25$ % of the weighing value.	To measure most precisely, but slow to stabilize
	*1	Stable when within $\pm 12.5$ % of the weighing value.	 To eliminate vibration and to stabilize quickly
	2	Stable when within $\pm 25$ % of the weighing value.	

\* factory setting

## Hold function-Example of use

1. Select 1 for the function setting, *bRSFnC*, *HoLd*. (model EK-600H illustrated)  
Set the weighing unit to one other than the counting mode.

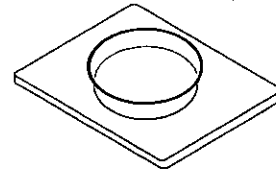

The weighing unit to one other than the counting mode.

2. Place a tare container on the pan and press **ZERO**. The display will show zero.

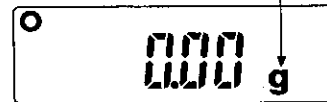

3. Place the animal in the tare container.

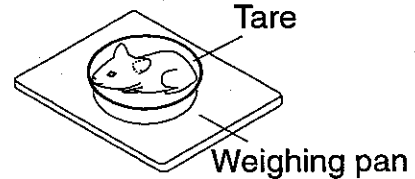

4. When the hold mark is lit, read the displayed weight.

Processing mark  
(Calculating the averaged value)

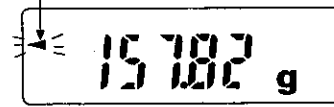

Hold mark

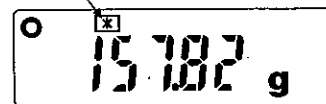

5. Remove the animal. The display will return to zero.

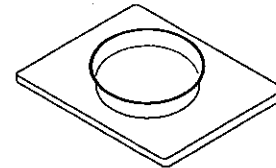

## 6. CALIBRATION

This function adjusts the balance for accurate weighing. Perform a calibration in the following case.

- When the balance is first used
- When the balance has been moved
- When the ambient environment has changed
- For periodic calibration

### 6-1. Calibration using a weight

1. Warm up the balance for at least half an hour with nothing on the pan.
2. Press and hold the **[SAMPLE]** and **[PRINT]** keys until **[CAL out]** appears, and release the keys.
3. The balance displays **[CAL 0]**.

To change the calibration weight value, proceed to step 4.

To use the calibration weight value in the balance memory, proceed to step 5.

4. Press the **[SAMPLE]** key. Use the following keys to change the value. Available weight values for each model are listed in Table 1. The fine value of weight setting range is  $\pm 10$  digits.

**[ZERO]** key: To set the value of the digit selected.

All digits blinking=Select a weight

Two least digits blinking=Set the fine value of weight (-10 digit comes after +10 digit.)

**[SAMPLE]** key To select the digit to change.

**[PRINT]** key To store the weight value and return to step 3.

**[MODE]** key To cancel the operation and return to step 3.

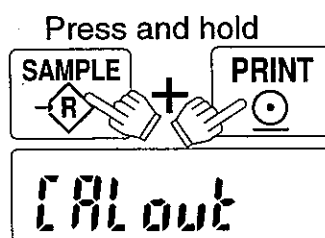

Release the keys

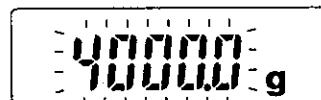
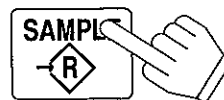
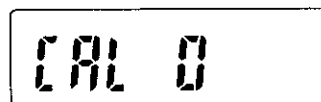

Set using the relevant keys.

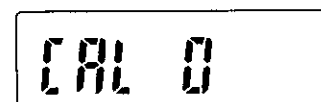
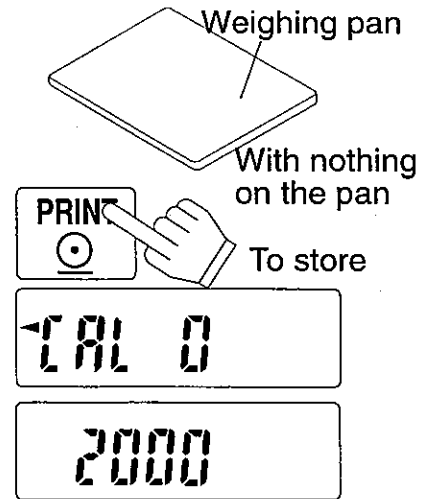

Table 1  
Weight values available

Model	EK-400H	EK-600H	EK-4000H	EK-6000H
Calibration weight	200g 300g 400g	300g 400g 500g 600g	2000g 3000g 4000g	3000g 4000g 5000g 6000g
Factory setting				

5. At step 3, pressing the **PRINT** key weighs the zero-point value. Do not touch the pan during weighing .



6. Place the calibration weight with the same value as displayed on the pan. Press the **PRINT** key to weigh it. Do not touch the balance during weighing.

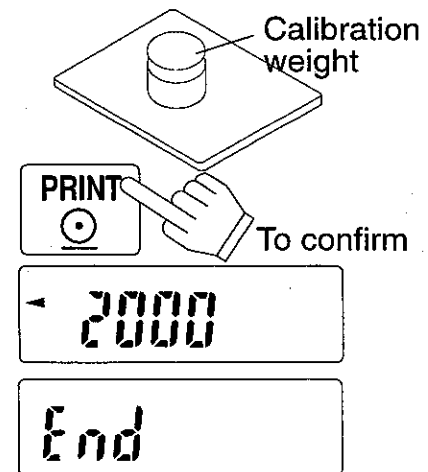

7. **End** appears.  
Remove the weight from the pan.
8. The balance returns to the weighing mode.

**Note:** *Whether or not to use this mode can be selected in "to permit or prohibit key operation". Refer to Page 20.*

## 7. SETTING RESPONSE CONDITION

Changes the response of the balance according to the ambient environment (breeze and vibration).

1. Press and hold the **[SAMPLE]** key. The balance displays **bASFnC** and enters the function setting mode.

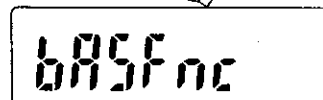

2. Press the **[PRINT]** key to display **[Cond]**.

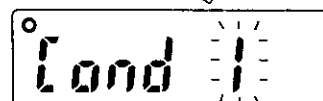
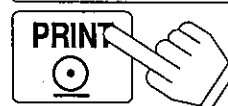

3. Press the **[ZERO]** key several times to select a parameter. (Refer to the function list on page 17.)

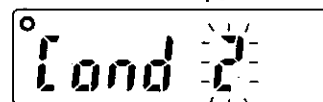

4. Press the **[PRINT]** key to store the new response parameter. **[CP Fnc]** appears after **[End]**.

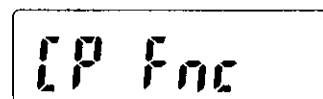
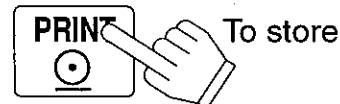

5. Press the **[MODE]** key to return to the weighing mode.

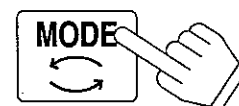

Returns to the weighing mode

### Response condition parameters

Cond 0	Quick weighing, sensitive value
Cond 1	↑
Cond 2	Slow weighing, stable value

## 8. FUNCTIONS

**Note:** Whether or not to use this mode can be selected in "permit or prohibit key operation". Refer to page 20.

### 8-1. Key operation

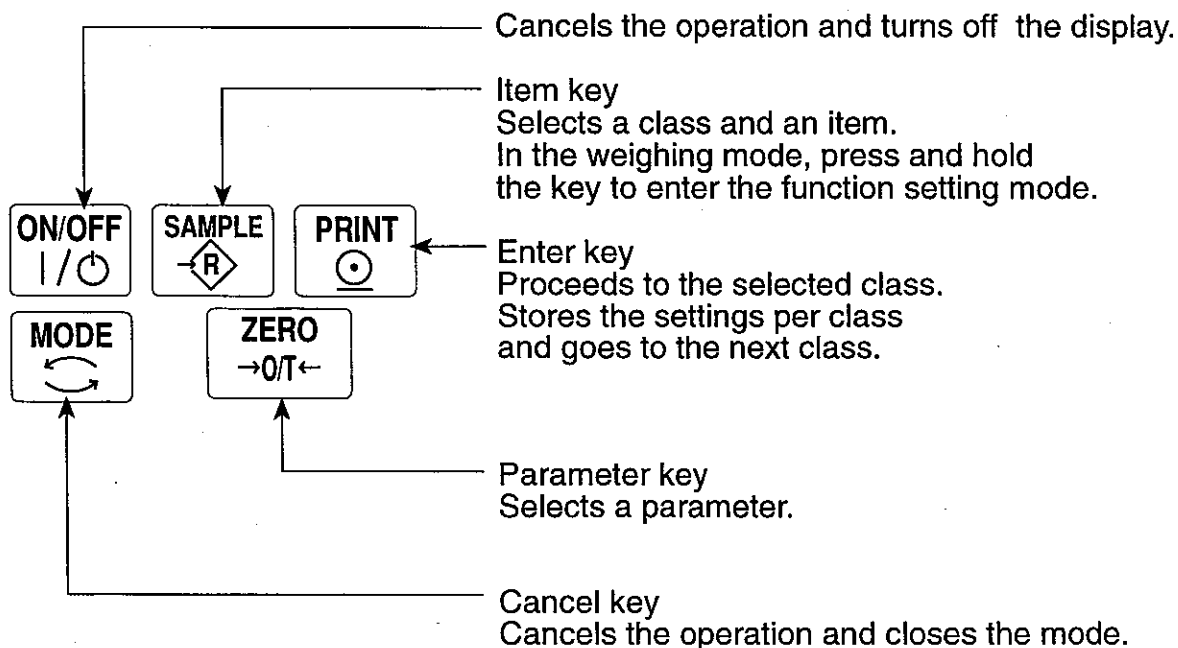

### 8-2. Entering the function setting mode.

In the weighing mode, press and hold the **SAMPLE** key to enter the function setting mode and display **bAS Fnc**. Each time the **SAMPLE** key is pressed, the class appears one after another.

Once the class is selected, the set items are available for selection. (Refer to "Function list".)

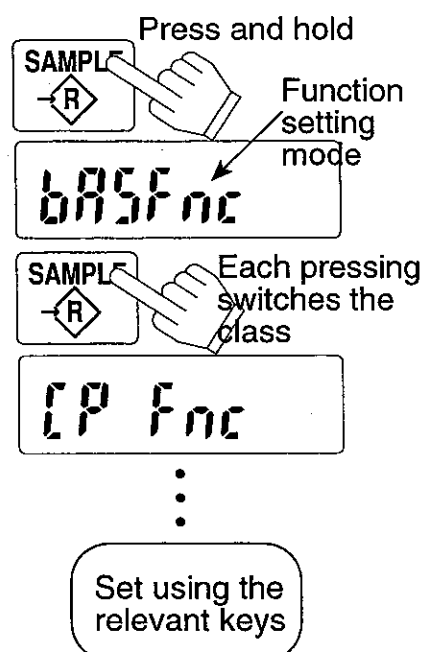

## 8-3. Setting example

To set the response of the balance to "Slow weighing, stable value" and the display refresh rate to "10 times/second".

1. Press and hold the **[SAMPLE]** key to display **[bRSFnc]**.

2. Press the **[PRINT]** key. The balance displays **[Lond]**.

3. Press the **[ZERO]** key several times to display **[Lond 1]**.

4. Press the **[SAMPLE]** key several times to select **[SPd]**.

5. Press the **[ZERO]** key several times to select **[SPd 1]**.

6. Press the **[PRINT]** key to store the parameters. **[LP Fnc]** appears after **[End]**.

7. Press the **[MODE]** key to return to the weighing mode.

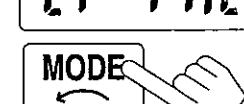
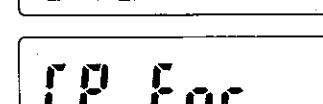
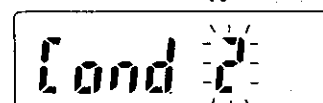
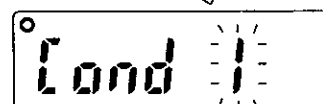
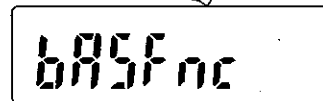

Returns to the weighing mode

## 8-4. Storing a weighing unit

It is possible to store only the units that will be actually used from the units available. For the units available, refer to "5-3.Units".

Store the selected unit as described below:

1. Press and hold the **SAMPLE** key to display **bR5Fnc**.

2. Press the **SAMPLE** key to display **Unit**.

3. Press the **PRINT** key.

4. Press the **SAMPLE** key several times to select a weighing unit.

5. Press the **ZERO** key to store the weighing unit.

6. Press the **PRINT** key. **id** appears after **End**.

7. Press the **MODE** key to exit the function setting mode. The balance returns to the weighing mode with the selected unit.



Press and hold

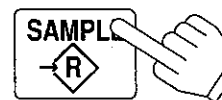
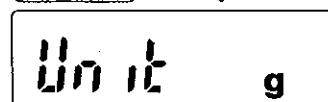
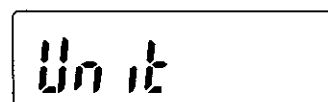
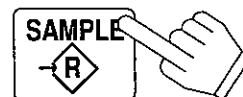
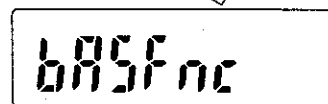

Each pressing switches the units available in the order described on page 5.

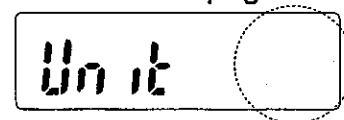

To store



To confirm

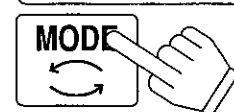
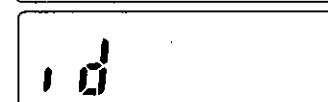

Returns to the weighing mode

## 8-5. Function list

Class	Item	Parameter	Description		
bRSFnc Environment Display	Lond Response	0	Quick weighing, sensitive value	For target weighing mode	
		1	↕	In the hold function, set the	
		2	Slow weighing, stable value	time to be averaged.	
	St-b Stability band width *1	0	Stable when within ±1 digit	↕	The stable indicator appears when the display fluctuation is within the range per second. In the hold function, set the width to be averaged.
		1			
		2	Stable when withing ±3 digits.		
	Hold Hold function	0	OFF	The display is held.	
		1	ON		
	Zrc Zero tracking	0	OFF	The function to keep zero display by tracking zero-drift	
		1	ON		
SPd Display refresh rate	0	5 times/second	The period to refresh the display		
	1	10 times/second			
Pnt Decimal point	0	Point (.)	The decimal point format		
	1	Comma (,)			
P-on Auto display-ON	0	<del>ON</del> OFF	The display turns on automatically, when AC adapter is connected.		
	1	<del>OFF</del> ON			
[P Fnc Comparator	[P Comparator mode	0	No comparison		
		1	Comparison, not near zero, when stable value or over		
		2	Comparison, near zero, when stable value or over		
		3	Continuous comparison, not near zero		
		4	Continuous comparison, near zero		
	[P in Input method	0	Digital input, upper/lower limits	[P H <sub>i</sub> or [P L <sub>o</sub> can be selected. [P rEF or [P Lnt can be selected.	
		1	Weighing input, upper/lower limits		
		2	Digital input, reference value		
		3	Weighing input, reference value		
	(Displayed only when OP-04H is connected.)	bEP <sub>-</sub> LO buzzer	0	OFF	Select whether or not to sound the buzzer at LO.
1		ON			
bEP <sub>-</sub> OK buzzer		0	OFF	Select whether or not to sound the buzzer at OK.	
1	ON				
bEP <sub>-</sub> HI buzzer	0	OFF	Select whether or not to sound the buzzer at HI.		
1	ON				
[P H <sub>i</sub> Upper limit			Refer to "9. Comparator".	Displayed when upper/lower limit is selected.	
[P L <sub>o</sub> Lower limit					
[P rEF Reference value			Refer to "9. Comparator".	Displayed when reference value is selected.	
[P Lnt Tolerance					

■ Factory setting

Continued

\*1 "Digit" is the minimum display unit.

Class	Item	Parameter	Description		
<i>dout</i> Data output  (Displayed only when OP-03H/05H are connected.)	<i>Prt</i> Data output mode	▪ 0	Key mode	PRINT key is accepted only when display is stable.	
		1	Auto print mode A (Reference=zero)	Data is output when display is stable and conditions of <i>RP-P</i> , <i>RP-b</i> and reference value are met.	
		2	Auto print mode B (Reference=last stable value)		
	<i>RP-P</i> Auto print polarity	3	Stream mode	Data is output continuously.	
		▪ 0	Plus only	Displayed value > Reference	
		1	Minus only	Displayed value < Reference	
	<i>RP-b</i> Auto print difference	2	Both polarities	Regardless of displayed value	
		▪ 0	10 digits	Difference between reference value and displayed value	
		1	100 digits		
	<i>PUSE</i> Data output pause	2	1000 digits		
		▪ 0	No pause	Selects output interval.	
	<i>Pt-F</i> Auto feed	1	Pause (1.5 seconds)		
		▪ 0	Not used	Whether or not to feed paper automatically after data output.	
	<i>info</i> GLP output	1	Used		
		▪ 0	No output	Selects the GLP data output format.	
		1	AD-8121 format		
	<i>Rr-d</i> Zero after output	2	Data format		
		▪ 0	Not displayed		
	<i>5IF</i> Serial interface  (Displayed only when OP-03H/05H are connected.)	<i>bps</i> Baud rate	1	Displayed	
			0	600 bps	
1			1200 bps		
▪ 2			2400 bps		
3			4800 bps		
<i>btPr</i> Length, parity bits		4	9600 bps		
		▪ 0	7 bits, EVEN		
		1	7 bits, ODD		
<i>CrLF</i> Terminator		2	8 bits, NON		
		▪ 0	CR LF	CR:ASCII 0Dh	
<i>TYPE</i> Data format		1	CR	LF:ASCII 0Ah	
		▪ 0	A&D format		
		1	DP format		
		2	KF format		
		3	MT format		
<i>t-UP</i> Time up		4	NU format		
		0	No limit	Selects the maximum wait time to receive command.	
<i>ErCd</i> AK, error code		▪ 1	For one second		
		▪ 0	No output	AK:ASCII 06h	
<i>CTS</i> CTS control		1	Output		
	▪ 0	Not used	Controls CTS and RTS. Set to 0 whenever printer is connected.		
		1	Used		

▪ Factory setting

Continued





Unit Unit	Refer to "5-3. Units" on page 5.
ID ID number	Refer to "10. ID number and GLP" on page 26.

## 8-6. Initial settings

The instrument parameters shown below can be restored to the factory settings using the following procedure.

Parameters to be restored:

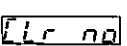
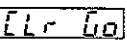
Function setting, calibration weight value, PCS, %, permit or prohibit key operation

1. Press the **ON/OFF** key to display .  
(Standby indicator)
2. While pressing and holding both the **SAMPLE** and **PRINT** keys, press the **ON/OFF** key. The balance displays .
3. Press the **SAMPLE** key to display .
4. Press the **PRINT** key to display .
5. Press the **ZERO** key to display .  
(Factory setting)
6. Press the **PRINT** key to restore the parameters to the factory settings. The balance displays .
7. The balance returns to the weighing mode.

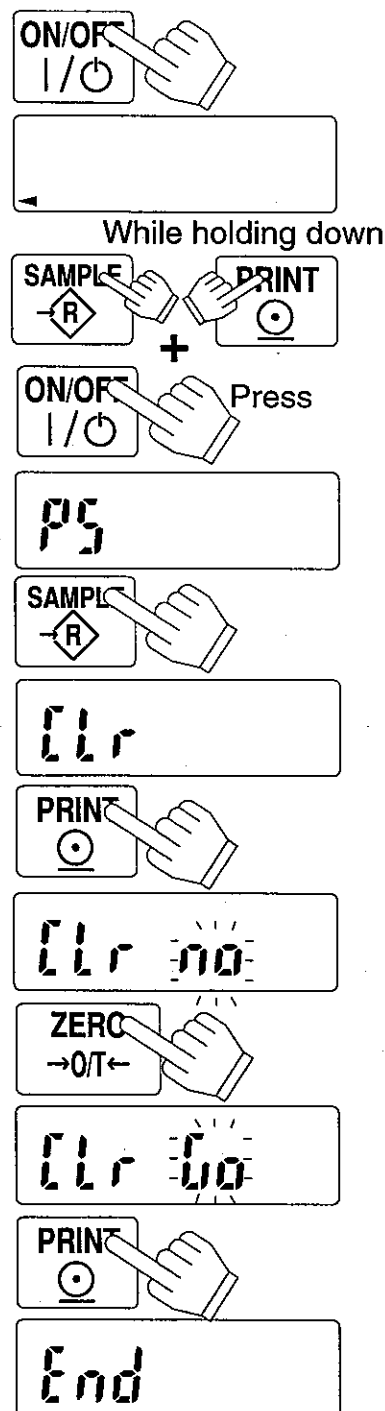

Returns to the weighing mode

## 8-7. To permit or prohibit key operation

Sets whether or not to permit changing the parameters stored in the balance memory.

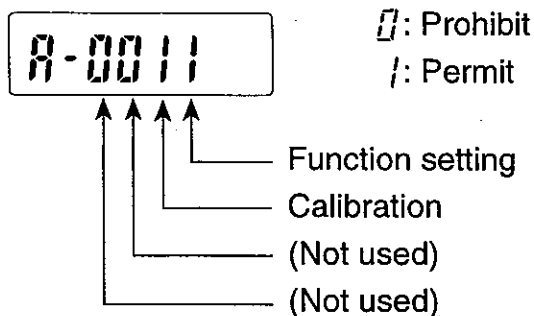

Factory setting



1. Press the **ON/OFF** key to display .  
(Standby indicator)



2. While pressing and holding both the **SAMPLE** and **PRINT** key, press the **ON/OFF** key.  
The balance displays .

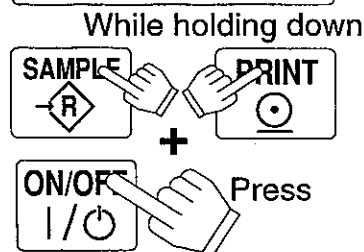

3. Press the **PRINT** key to display .

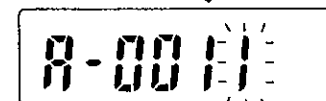

4. Make a change with the following keys.

**ZERO** key To change the condition of the digit selected.

**SAMPLE** key To select the digit to change.

**PRINT** key To store the new settings (**End** appears after storage.) and proceed to the next step.

**MODE** key To cancel the operation. Press the key twice to proceed to the next step.

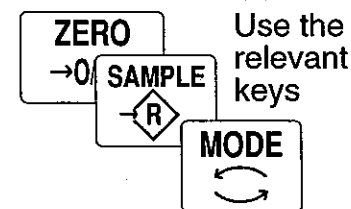

5. The balance will return to the weighing mode.

Returns to the weighing mode

## 9. COMPARATOR

The results of the comparison are indicated by **[HI]** **[OK]** **[LO]** on the display.

Operating conditions: No comparison (comparison turned off)

Comparison at stable value or over, not near zero

Comparison at stable value or over, near zero

Continuous comparison, not near zero

Continuous comparison, near zero

To compare, use: Upper limit value and lower limit value

Reference value plus and minus a tolerance value

Input methods: Digital input, Weighing input

Refer to the function list about the meaning of **[P Fnc]**.

Whenever the weighing unit is changed, re-enter the comparator value.

### 9-1. Setting example 1

This example will use :

"Continuous comparison, not near zero",

"Reference value and a tolerance value"

and "Digital input".

#### Selecting a comparison method

1. Press and hold the **[SAMPLE]** key to display **[bRSFnc]**.

2. Press the **[SAMPLE]** key several times to display **[P Fnc]**.

3. Press the **[PRINT]** key.

4. Press the **[ZERO]** key several times to display **[P 3]**.

5. Press the **[SAMPLE]** key to display **[P in]**.

6. Press the **[ZERO]** key several times to display **[P in 2]**.

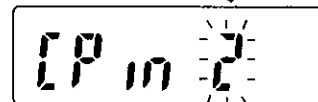
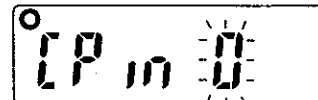
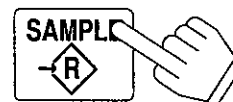
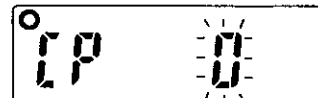
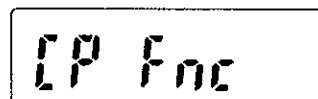
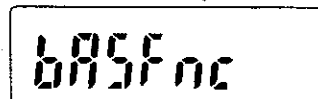

7. Press the **PRINT** key to store the settings.

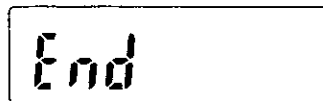
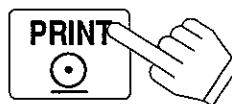

## Entering the reference and tolerance values

8. With **CP rEF** displayed, press the **PRINT** key. All the digits blink. Press the **ZERO** key. Enter the reference value with the following keys.

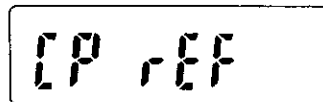

**SAMPLE** key To select the digit to change.



**ZERO** key To set the value of the digit selected. Hold down the key to switch the polarity.



**PRINT** key To store the value and proceed to the next step.



**MODE** key To cancel the value and proceed to the next step.



Set using the relevant keys

9. With **CP Lnt** displayed, press the **PRINT** key. Enter the tolerance value in percentage to the reference value as 100%, using the following keys.

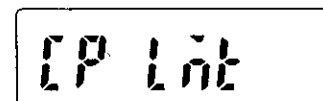

**SAMPLE** key To select the digit to change.



**ZERO** key To set the value of the digit selected.



**PRINT** key To store the value and proceed to the next step.

Set using the relevant keys

**MODE** key To cancel the value and proceed to the next step.

10. Press the **PRINT** key. **dout** appears after **End**.

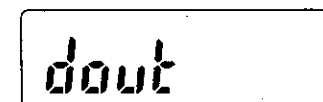
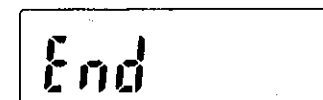

11. Press the **MODE** key to return to the weighing mode.



Returns to the weighing mode

## 9-2. Setting example 2

This example will use "Continuous comparison, near zero", "Upper limit/ lower limit" and "Digital input".

### Selecting a comparison method

1. Press and hold the **SAMPLE** key to display **685Fnc**. (See Example 1 for the detail about steps 1-7.)
2. Press the **SAMPLE** key to display **[P Fnc]**.
3. Press the **PRINT** key to display **[P]**.
4. Press the **ZERO** key several times to display **[P 4]**.
5. Press the **SAMPLE** key several times to display **[P in]**.
6. Press the **ZERO** key several times to display **[P in 0]**.
7. Press the **PRINT** key to store the selection.

⋮

See Example 1

### Entering the upper and lower limit values

8. With **[P H]** displayed, press the **PRINT** key. All the digits blink. Press the **ZERO** key. Enter the upper limit value using the following keys.

**SAMPLE** key To select the digit to change.

**ZERO** key To set the value of the digit selected. Hold down the key to switch the polarity.

**PRINT** key To store the value and proceed to the next step.

**MODE** key To cancel the value and proceed to the next step.

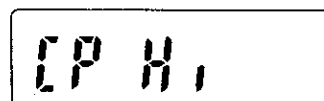

Set using the relevant keys



9. With **[CP Lo]** displayed, press the **[PRINT]** key. All the digits blink. Press the **[ZERO]** key. Enter the lower limit value using the following keys.

**[SAMPLE]** key To select the digit to change.

**[ZERO]** key To set the value of the digit selected.

**[PRINT]** key To store the value and proceed to the next step.

**[MODE]** key To cancel the value and proceed to the next step.

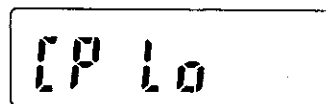

Set using the relevant keys

10. Press the **[PRINT]** key. **[dout]** appears after **[End]**.

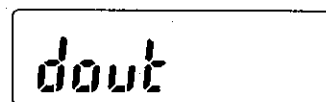
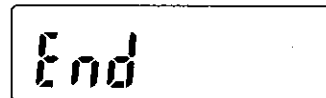

Returns to the weighing mode

11. Press the **[MODE]** key to return to the weighing mode.

## 9-3. Setting example 3

This example will use "Comparison at stable value or over, near zero", "Upper limit / lower limit" and "Weighing input".

### Selecting a comparison method (See example 1)

1. Press and hold the **[SAMPLE]** key to display **[bRSFnC]**. (See Example 1 for the detail about steps 1-7.)
2. Press the **[SAMPLE]** key to display **[CP Fnc]**.
3. Press the **[PRINT]** key to display **[CP]**.
4. Press the **[ZERO]** key several times to display **[CP 2]**.
5. Press the **[SAMPLE]** key several times to display **[CP in]**.
6. Press the **[ZERO]** key several times to display **[CP in 1]**.
7. Press the **[PRINT]** key to store the selection.

## Entering the upper and lower limit values

8. With **[P Hi]** displayed, press the **[PRINT]** key. All the digits blink. Press the **[ZERO]** key. The weighed value is displayed.

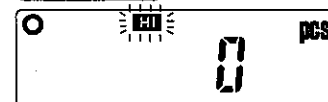
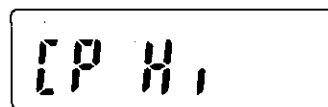

9. Place a sample whose weight corresponds to the upper limit value on the pan. Press the **[PRINT]** key to store the weight. Remove the sample. Press the **[ZERO]** key to display zero.

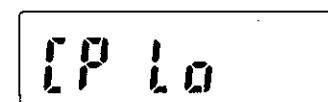
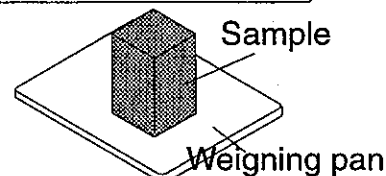

10. **[P Lo]** appears after the above operation has completed.



11. With **[P Lo]** displayed, press the **[PRINT]** key. All the digits blink. Press the **[ZERO]** key. The weighed value is displayed.

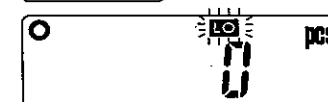

12. Place a sample whose weight corresponds to the lower limit value on the pan. Press the **[PRINT]** key to store the weight. Remove the sample. Press the **[ZERO]** key to display zero.

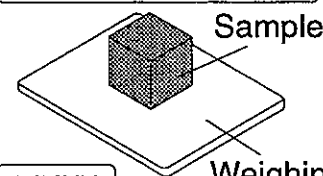

13. Press the **[PRINT]** key. **dout** appears after **End**.

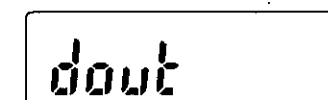
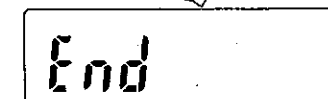

14. Press the **[MODE]** key to return to the weighing mode.



Returnst to the weighing mode

## 10. ID NUMBER AND GLP

The ID number is used to identify the balance when Good Laboratory Practice (GLP) is used. The following GLP data is transmitted to an AD-8121 printer or a computer using option OP-03H or OP-05H.

- The result of calibration
- The result of calibration test

**Note:** Option OP-03H or OP-05H is needed to achieve this data output. The data format conforms to *INF0* of the function list. Refer to the options manual.

### 10-1. Setting the ID number

1. Press and hold the **SAMPLE** key to display **bR5Fnc**.

2. Press the **SAMPLE** key several times to display **id**.

3. Press the **PRINT** key. Enter the ID number using the following keys.

**ZERO** key To set the character of the digit selected. Refer to the table below for the "display character set".

**SAMPLE** key To select the digit to change.

**PRINT** key To store the value and proceed to the next step.

**MODE** key To cancel the value and proceed to the next step.

4. When the above operation has completed, **bR5Fnc** appears after **End**.

5. Press the **MODE** key to return to the weighing mode.



Press and hold

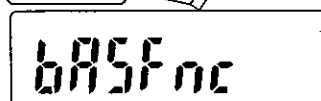

Press several times

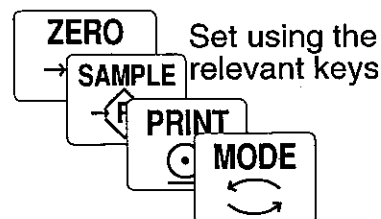

Set using the relevant keys

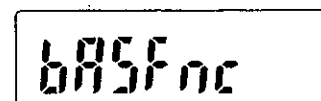
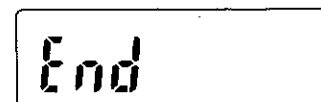

Returns to the weighing mode

#### Display character set

0	1	2	3	4	5	6	7	8	9	-	_	A	B	C	D	E	F	G	H	I	J	K	L	M	N	O	P	Q	R	S	T	U	V	W	X	Y	Z
0	1	2	3	4	5	6	7	8	9	-	_	R	b	[	d	E	F	G	H	i	d	L	n	n	o	P	q	r	S	t	U	v	w	x	y	z	

\_ Space

## 10-2. Calibration test

### Calibration test using a weight

The calibration test mode is used to confirm accurate weighing.

1. Press and hold the **SAMPLE** and **PRINT** keys. **[[ out** appears after **[RL out**. Release the keys when **[[ out** is displayed.

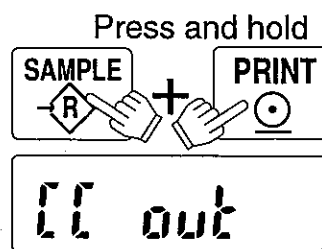

2. **[[ 0** is displayed.

Release the keys

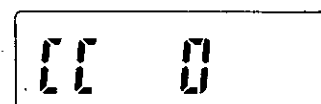

3. Press the **SAMPLE** key and change the weight value using the following keys.

**ZERO** key To set the value of the digit selected.

**SAMPLE** key To select the digit to change.

**PRINT** key To store the value and return to step 2.

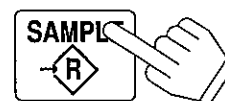

Set using the relevant keys

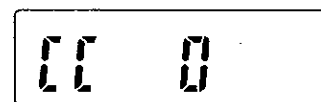

4. At step 2, press the **PRINT** key. The zero point is weighed and is displayed for a few seconds.

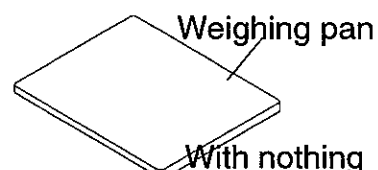

With nothing on

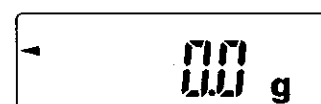

5. Place a weight, with the same value as displayed, on the pan. Press the **PRINT** key to weigh it. The weighed value is displayed for a few seconds.

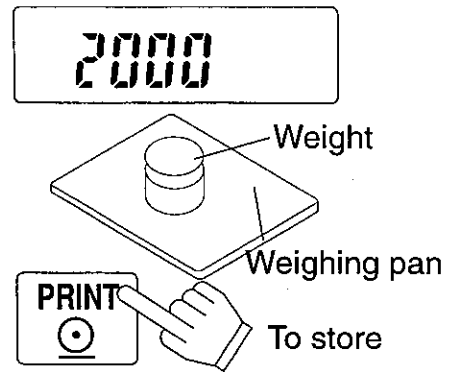

6. **End** appears. Remove the weight.

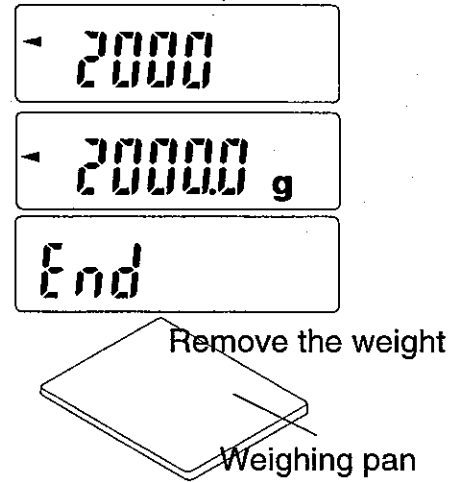

7. **OLP** is displayed and the data is output.

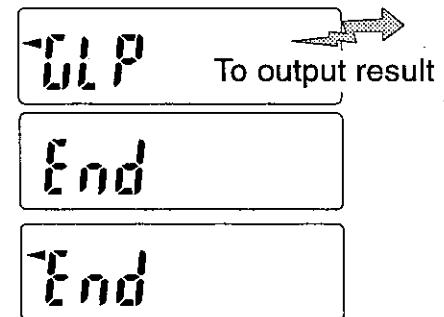

8. The balance will return to the weighing mode.

Returns to the weighing mode

## 10-3. Output examples

### Data format for calibration

#### AD-8121 format

```

      A & D
MODEL   EK-600H
S/N     1234567
ID      ABCDEF
DATE    97/01/14
02:53:21 PM
CALIBRATED(EXT.)
CAL.WEIGHT
      +500.00 g
SIGNATURE
-----
    
```

← Manufacturer →  
 ← Model →  
 ← Serial number →  
 ← ID number →  
 ← Date →  
 ← Time →  
 ← Calibration →  
 ← Calibration weight value →  
 ← Column for signature →

#### Data format

```

      A & D<TERM>
MODEL   EK-600H<TERM>
S/N     1234567<TERM>
ID      ABCDEF<TERM>
DATE<TERM>
<TERM>
TIME<TERM>
<TERM>
CALIBRATED(EXT.)<TERM>
CAL.WEIGHT<TERM>
      +500.00 g<TERM>
SIGNATURE<TERM>
<TERM>
<TERM>
-----<TERM>
<TERM>
<TERM>
    
```

### Data format for calibration test

#### AD-8121 format

```

      A & D
MODEL   EK-600H
S/N     1234567
ID      ABCDEF
DATE    97/01/14
03:15:40 PM
CAL.TEST(EXT.)
ACTUAL
      0.00 g
      +500.00 g
TARGET
      +500.00 g
SIGNATURE
-----
    
```

← Manufacturer →  
 ← Model →  
 ← Serial number →  
 ← ID number →  
 ← Date →  
 ← Time →  
 ← Calibration test →  
 ← Zero point vaue →  
 ← Actual weight value →  
 ← Target weight value →  
 ← Column for signature →

#### Data format

```

      A & D<TERM>
MODEL   EK-600H<TERM>
S/N     1234567<TERM>
ID      ABCDEF<TERM>
DATE<TERM>
<TERM>
TIME<TERM>
<TERM>
CAL.TEST(EXT.)<TERM>
ACTUAL<TERM>
      0.00 g<TERM>
      +500.00 g<TERM>
TARGET<TERM>
      +500.00 g<TERM>
SIGNATURE<TERM>
<TERM>
<TERM>
-----<TERM>
<TERM>
<TERM>
    
```

~ Space, ASCII 20h  
 <TERM> Terminator, CR, LF, or CR  
 CR Carriage return, ASCII 0Dh  
 LF Line feed, ASCII 0Ah

---

## 11. OPTIONS

---

The following options are available to be purchased separately.

- (1) OP-03H RS-232C serial interface
- (2) OP-04H Comparator relay output
- (3) OP-05H Printer interface (Current loop output)
- (4) OP-07H Underhook
- (5) OP-09H NiCd battery pack

**Note:** *OP-03H, OP-04H, and OP-05H can not be used at the same time.*

*Refer to the options manual for details.*

*The current loop interface is a passive type and requires an external power source that can supply 20mA. The external power source is not necessary when connecting an AD-8121.*

## 12. MAINTENANCE

### 12-1. Notes on maintenance

- Do not disassemble the balance. Contact your local A&D dealer if your balance needs service or repair.
- Please use the original box for transportation.
- Do not use organic solvents to clean the balance. Use a warm lint free cloth dampened with a mild detergent.

### 12-2. Error codes

- Overload error**

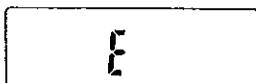

Warning to indicate that an object beyond the balance capacity has been placed on the pan. Remove the object from the pan.

- Weighing pan error**

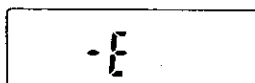

Warning to indicate that the weighing value is too light. Confirm that the weighing pan is properly installed. Try to see if calibration will solve the problem.

- Unit weight error**

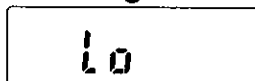

The sample weight is too light to set the unit weight in the counting mode.

- Sample quantity notice**

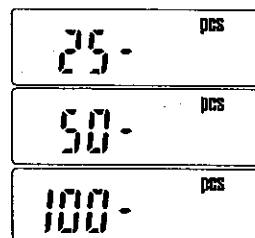

When samples are light and the counting error could become large, the balance requests you to add the number of samples displayed to those already on the pan. Place them on the pan and press the **PRINT** key to store the correct value.

**Note:** *Pressing the **PRINT** key without adding samples may reduce counting accuracy.*

- CAL errors**

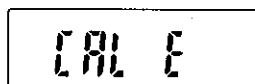

Warning to indicate that calibration has been canceled because the calibration weight is too heavy. Confirm that nothing is on the pan. Press the **MODE** key to return to the weighing mode.

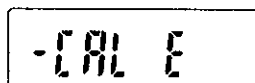

Warning to indicate that calibration has been canceled because the calibration weight is too light. Confirm that the weighing pan is properly installed. Press the **MODE** key to return to the weighing mode.

- Stability error**

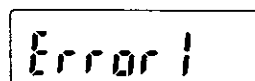

Warning to indicate that the weight value is not stable and the balance can not display it. Prevent vibration and drafts. Press the **MODE** key to return to the weighing mode.

***If you can not cancel the error or other errors occurred, request service from the store where you purchased the balance, or from the A&D dealer.***

## 13. SPECIFICATIONS

	EK-400H	EK-600H	EK-4000H	EK-6000H
Weighing capacity (g)	400	600	4000	6000
Minimum display (g)	0.01 / 0.1		0.1 / 1	
Number of samples (pcs.)	10, 25, 50, or 100			
Maximum countable number (pcs.)	40000	60000	40000	60000
Minimum unit weight (g)	0.01		0.1	
Minimum % display (%)	0.01 / 0.1 / 1			
Minimum % weight (g)	1.00		10.0	
Display	7-segment LCD (Character height =16 mm)			
Admissible ambient temperature	5-40°C (41-104°F)		Relative humidity 85% or less No condensation	
Repeatability (Standard deviation)	0.01 g		0.1 g	
Linearity	±0.02 g		±0.2 g	
Sensitivity drift	±10ppm / °C (10-30°C)			
Display refresh rate (Approx.)	5 times/second (10 times/second for high speed)			
Power supply	AC adapter or NiCd battery (Option) Confirm that the AC adapter is correct for the receptacle type and voltage.			
Battery operating hours	Approx. 8 hours (Approx.6 hours using with options)			
Weighing pan size	133 mm × 170 mm			
Mass (Approx.)	1.5 kg		1.6 kg	
Calibration weight (g) ▪ Factory setting	200	300	2000	3000
	300	400	3000	4000
	▪ 400	▪ 500	▪ 4000	▪ 5000
		600		6000

## External dimensions

